

A1 INSTALLATION DRAWING

IF THIS DOCUMENT IS PRINTED IN HARDCOPY, IT IS FOR INFORMATION USE ONLY AND THEREFORE IS NOT SUBJECT TO UPDATING CONTROLS. ALWAYS REFER TO SOLIDWORKS VIEWER FOR LATEST ISSUE



THIS DRAWING IS CONFIDENTIAL AND IS SUPPLIED ON THE EXPRESS CONDITION THAT IT SHALL NOT BE LOANED OR COPIED OR DISCLOSED TO ANY OTHER PERSON OR USED FOR ANY OTHER PURPOSE WITHOUT THE WRITTEN CONSENT OF AP RACING LTD.



AP Racing
Wheler Road
Coventry
CV3 4LB

Tel: +44 (0) 24 7663 9595
Fax: +44 (0) 24 7663 9559
e-mail: engineering@aprac.com
Web site: <http://www.aprac.com>

© AP Racing Ltd. 2005

Issue No.	Alterations		Zone	Initials
	Date & No.	Particulars		
1	29/01/09 B5444	FIRST ISSUE		SAT
2	09/02/2010 B5815	DIM 51.46 ADDED	7K	SAT

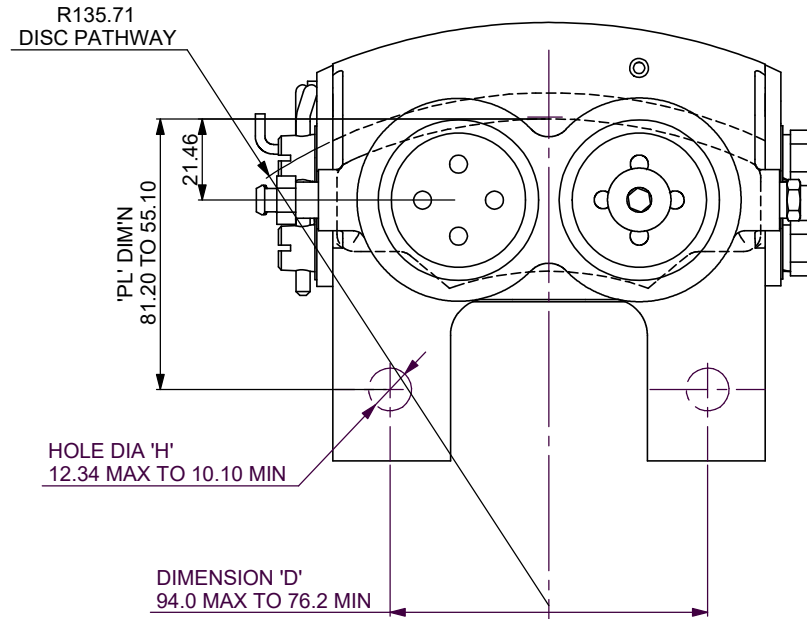
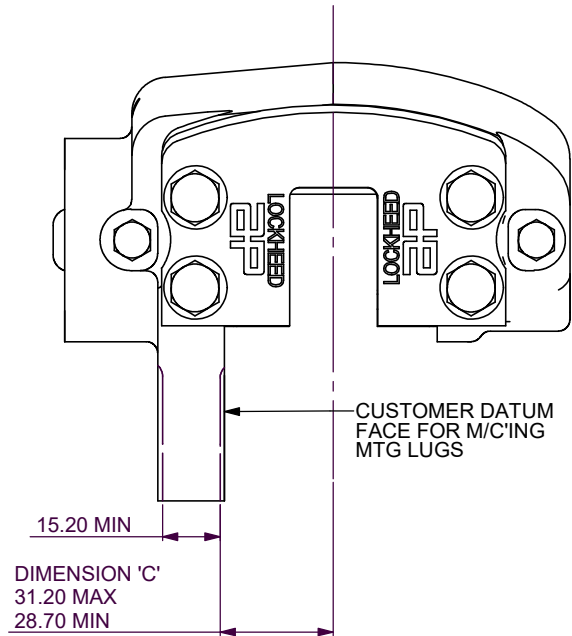

GENERAL DESCRIPTION:

THIS IS A 4 PISTON CLOSED BACK CALIPER WITH BLANK MOUNTING LUGS. THE MOUNTING LUGS MAY BE MACHINED WITHIN THE PARAMETERS GIVEN. IT IS DESIGNED TO OPERATE ON A CAST IRON DISC Ø267.0 - Ø267.0 x 20.7 THICK.

QUICK RELEASE END PLATES ARE AVAILABLE TO ENABLE RAPID PAD REPLACEMENT SEALS ARE HIGH TEMPERATURE 'SEAL-IN-BORE' TYPE.

TYPICAL APPLICATION:

HISTORIC SPORTS CARS & RALLY

TECHNICAL INFORMATION:

TOTAL PISTON AREA: 45.60cm²
PISTON MATERIAL: ALUMINIUM ALLOY
BODY MATERIAL: ALUMINIUM ALLOY
ALL HYDRAULIC CONNECTIONS: 3/8" x 24UNF
PISTON ANTI-KNOCK BACK SPRINGS (4lb) FITTED
ASSEMBLY WEIGHT: 2.0 Kg. (WITHOUT PADS)

INSTALLATION INFORMATION:

DISC & CALIPER MOUNTING TOLERANCES TO BE SUCH THAT THE DISC IS CENTRAL TO THE CALIPER TO WITHIN ±0.5mm.

KEY TO DIMENSIONS:

DIMENSION 'PL': TOP OF PAD MATERIAL TO MOUNTING HOLE CENTRE LINE WITH PAD SITTING DOWN ON LEDGE. TO BE SET BY THE CUSTOMER WITHIN THE PARAMETERS GIVEN.

DIMENSION 'U': WHEEL CENTRE LINE TO CALIPER MOUNTING HOLE CENTRE LINE, DETERMINED USING THE FOLLOWING FORMULA.

$$(DISC DIA / 2) + 0.5 - DIMENSION 'PL'. (UNITS mm).$$

THIS FORMULA APPLIES TO DISCS UP TO Ø302.0 FOR DISCS LARGER THAN THIS IT MAY BE NECESSARY TO INCREASE THE PAD OVERLAP TO GREATER THAN THE 0.5mm IN THE FORMULA. THE CRITERIA WILL BE TO ENSURE THE DISC IS RADIALLY CLEAR OF THE END PLATE SLOT BY 2.0mm MINIMUM.

DIMENSION 'C': OFFSET. DISC CENTRE LINE TO MOUNTING FACE. TO BE SET BY THE CUSTOMER WITHIN THE PARAMETERS GIVEN.

AP RACING TECHNICAL SECTION WILL BE PLEASED TO ADVISE ON THE MOST SUITABLE EQUIPMENT FOR ANY PARTICULAR APPLICATION.

PART NUMBERS:

CP2361-96S4QR - RIGHT HAND ASSEMBLY
CP2361-97S4QR - LEFT HAND ASSEMBLY

REPLACEMENT SEAL KIT:

SEAL KIT (HIGH TEMPERATURE) CP4518-JJ

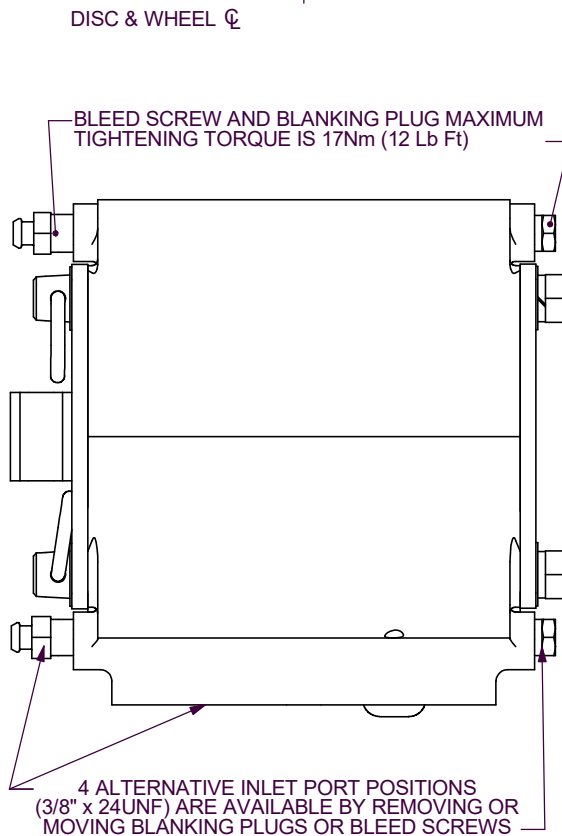
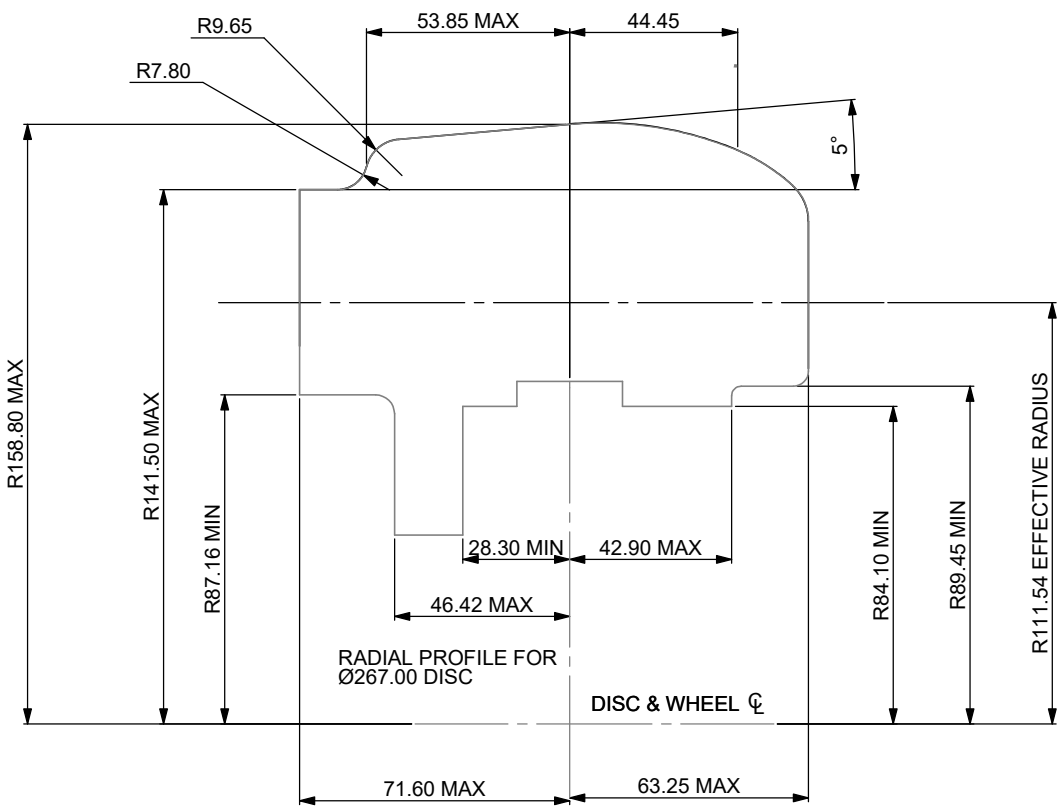

CALIPER IS HANDED BY THE POSITION OF THE CROSS DRILLING. THE BLEED SCREWS ARE FITTED TO THE OPPOSITE END TO THE CROSS DRILLING AND SHOULD BE UPPERMOST ON INSTALLATION

RH CALIPER IS SHOWN

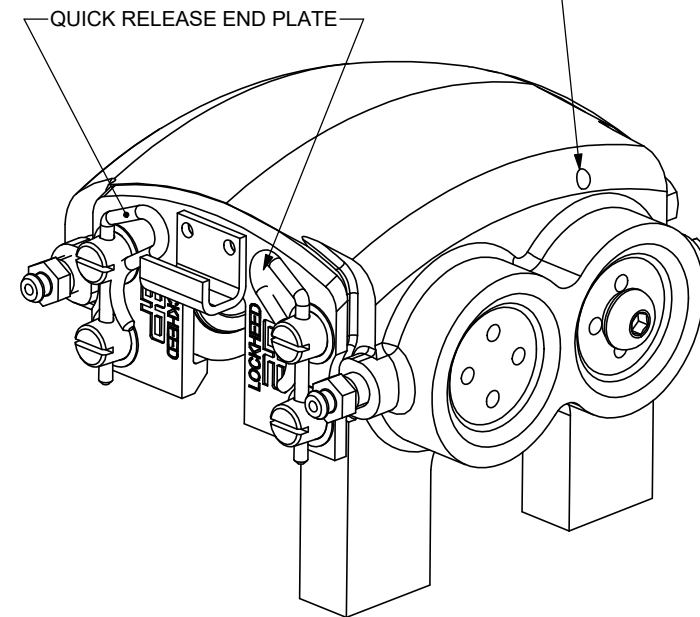

PAD FAMILY CP2340D43

PAD AREA:
- SLOTTED : 40.14 cm²
- FULL AREA : 41.54 cm²

PAD VOLUME:
- SLOTTED : 46.16 cm³
- FULL AREA : 47.77 cm³

PAD FAMILY CP2340D51

PAD AREA:
- SLOTTED : 43.36cm²
- FULL AREA : 45.04cm²

PAD VOLUME:
- SLOTTED : 49.86cm³
- FULL AREA : 51.79cm³

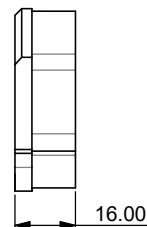
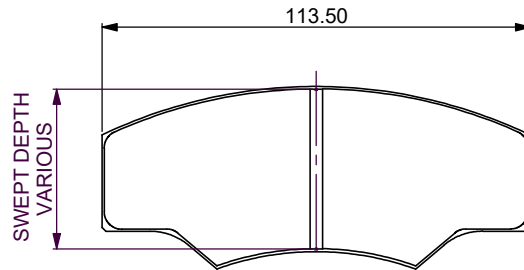

SCALE 1:1 SHEET 1 OF 1

DRAWN Steve Thomas

APPROVED

DERIVED FROM

TITLE

INSTALLATION OF 4 x 1.50" CLOSED BLOCK CALIPER

DRG NO. CP2361-1CD