

A2 INSTALLATION DRAWING

If this document is printed in hardcopy, it is for information use only and therefore is not subject to updating controls. Always refer to viewer for latest issue.

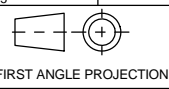

THIS DRAWING IS CONFIDENTIAL AND IS SUPPLIED ON THE EXPRESS CONDITION THAT IT SHALL NOT BE LOANED OR COPIED OR DISCLOSED TO ANY OTHER PERSON OR USED FOR ANY OTHER PURPOSE WITHOUT THE WRITTEN CONSENT OF AP RACING LTD.



AP Racing
Wheler Road
Coventry
CV3 4LB

Tel: +44 024 7663 9595
Fax: +44 024 7663 9559
e-mail: sales@ap racing.co.uk
Web site: http://www.ap racing.com

© AP Racing Ltd. 2016

FIGURE 1: BALANCE BAR ASSEMBLY

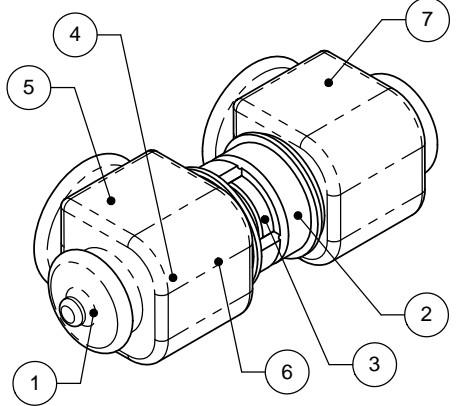

BILL OF MATERIAL:

1. BALANCE BAR
2. SLEEVE
3. SPHERICAL BEARING
4. BARREL NUT
5. CLEVIS
6. WASHER
7. BOOT

THE ASSEMBLY IS SUPPLIED WITH:
- 2 M3x0.5 GRUB SCREWS FOR CABLE FITTING (TAPPED HOLE IN BALANCE BAR)
- 1 BISSEL PIN ϕ 3x30 MM

BALANCE BAR ASSEMBLY PART No'S
CP5500-9
CP5500-9UNF

BALANCE BAR ASSEMBLY INSTALLATION

- A. SLEEVE**
1. MAKE A HOLE IN THE PEDAL OF THE RECOMMENDED DIMENSIONS (FIG.2). THE CENTER HAS TO BE AT THE SAME HEIGHT AS THE MASTER-CYLINDER CENTERLINE WHEN PEDAL IS SQUARE TO THE MASTER-CYLINDER.
 2. IF YOU WISH TO RETAIN THE SLEEVE WITH A BISSEL PIN, DRILL A HOLE IN THE PEDAL AS SHOWN ON FIGURE 2.
 3. POSITION THE SLEEVE IN THE PEDAL. IT IS RECOMMENDED TO BOND THE SLEEVE INTO THE HOUSING TO MINIMIZE THE PLAY OF THE BALANCE BAR. DEPENDING ON THE CONFIGURATION YOU CHOSE, PUT THE CIRCLIPS OR THE BISSEL PIN IN PLACE.
- B. BALANCE BAR INSTALLATION**
1. GREASE THE HOUSING INSIDE DIAMETER (2) AND THE SPHERICAL BEARING (3).
 2. INSTALL BALANCE BAR (1) INSIDE THE SLEEVE (3).
 3. INSTALL THE CLEVIS (5), BARREL NUT (4) AND WASHERS (6) INTO THE RUBBER BOOTS. HANG CLEVIS TO BOOT WITH GROOVE ON FRONT OF CLEVIS.
 4. SCREW THE BARREL NUTS (4) ON THE BALANCE BAR (1). LEAVE ONE TURN MINIMUM CLEARANCE BETWEEN THE CLEVIS (5) AND THE WASHERS (6).
 5. INSTALL REMOTE CABLE AND RETAINING SCREWS.
 6. INSTALL M8 NUTS PROVIDED ON MASTER-CYLINDER PUSHRODS.
 7. ADJUST THE PUSHRODS SO THAT THE BALANCE BAR IS PERPENDICULAR TO THE PUSHRODS UNDER MAXIMUM LOAD. THE SYSTEM IS THEN SQUARE. IT IS NOT IMPORTANT THAT THE SYSTEM IS SQUARE WHEN RELEASED, BUT IT HAS TO BE UNDER LOAD.

FOR MAXIMUM EFFICIENCY, IT IS RECOMMENDED THAT THE PEDAL IS AT RIGHT ANGLE WITH THE PUSHRODS UNDER MAXIMUM BRAKING LOAD.

ALSO MAKE SURE THAT THE MASTER-CYLINDER PISTONS FULLY RETURN BEFORE USE. THIS CAN BE CHECKED BY FEELING THE PUSHRODS FOR SLIGHT MOVEMENTS. THERE SHOULD NOT BE ANY EXCESSIVE LOOSE MOVEMENT.

THE WASHERS (6) SHOULD BE LOOSE DURING THE FULL PEDAL TRAVEL. IF NOT, BACK OFF ONE CLEVIS AND BARREL NUT ANOTHER TURN.

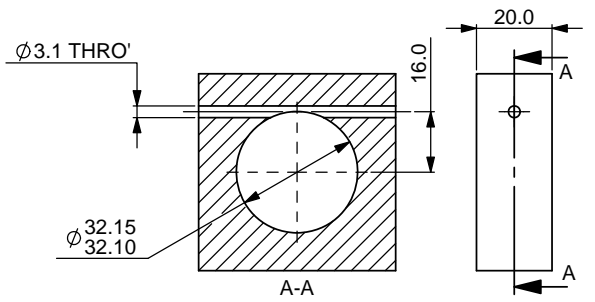

FIGURE 2: RECOMMENDED HOUSING DIMENSIONS

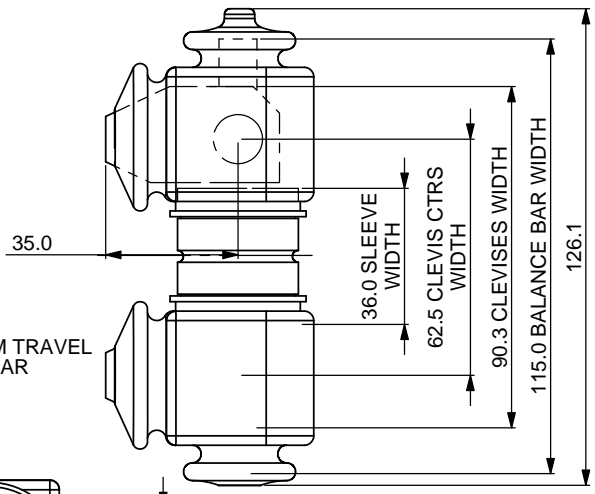
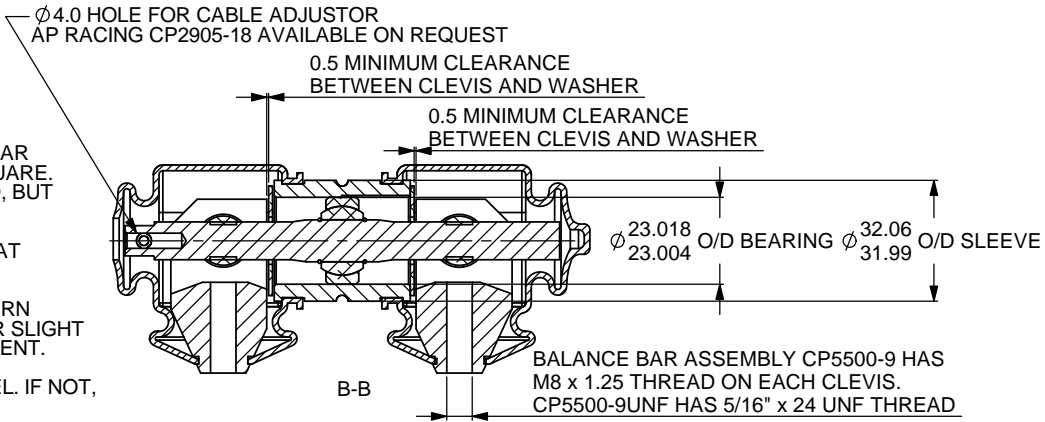
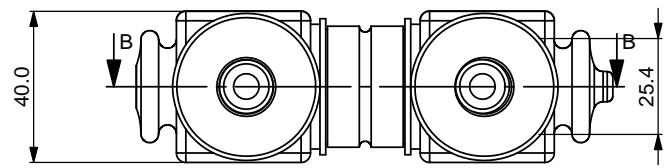

FIGURE 3: MAIN DIMENSIONS

MAXIMUM ARTICULATION +/-20°
IN CASE OF ONE CIRCUIT FAILURE, MAXIMUM TRAVEL BEFORE BRAKING IS 6.55 MM ON BALANCE BAR



BALANCE BAR ASSEMBLY CP5500-9 HAS M8 x 1.25 THREAD ON EACH CLEVIS.
CP5500-9UNF HAS 5/16" x 24 UNF THREAD

Issue No.	Date & No.	Alterations		Zone	Initials
		Particulars			
1	06/06/01 B2912	FIRST ISSUE			GM
2	05/09/02 B3425	5/16" UNF OPTION ADDED		#	DRA
3	01/05/03 RAC20366	5/16" UNF OPTION ADDED		B8	GM
4	22/03/2019 B8046	REMOVED 2 EXTERNAL CIRCLIPS Ø32 NOTE		G4	JDD
		FIXED HOUSING DIMENSIONS VIEWS		G8	
		ADDED MAIN DIMENSION LABELS		E10	

SCALE 1:1	SHEET 1 OF 1
DRAWN	jdavies
APPROVED	
DERIVED FROM	
TITLE ASSEMBLY DRAWING BALANCE BAR	
DRG NO.	CP5500-9