

A1 INSTALLATION DRAWING

IF THIS DOCUMENT IS PRINTED IN HARDCOPY, IT IS FOR INFORMATION USE ONLY AND THEREFORE IS NOT SUBJECT TO UPDATING CONTROLS. ALWAYS REFER TO SOLIDWORKS VIEWER FOR LATEST ISSUE



THIS DRAWING IS CONFIDENTIAL AND IS SUPPLIED ON THE EXPRESS CONDITION THAT IT SHALL NOT BE LOANED OR COPIED OR DISCLOSED TO ANY OTHER PERSON OR USED FOR ANY OTHER PURPOSE WITHOUT THE WRITTEN CONSENT OF AP RACING LTD.



AP Racing
Wheler Road
Coventry
CV3 4LB

Tel: +44 (0) 24 7663 9595
Fax: +44 (0) 24 7663 9559
e-mail: engineering@apracings.com
Web site: <http://www.apracings.com>

© AP Racing Ltd. 2005

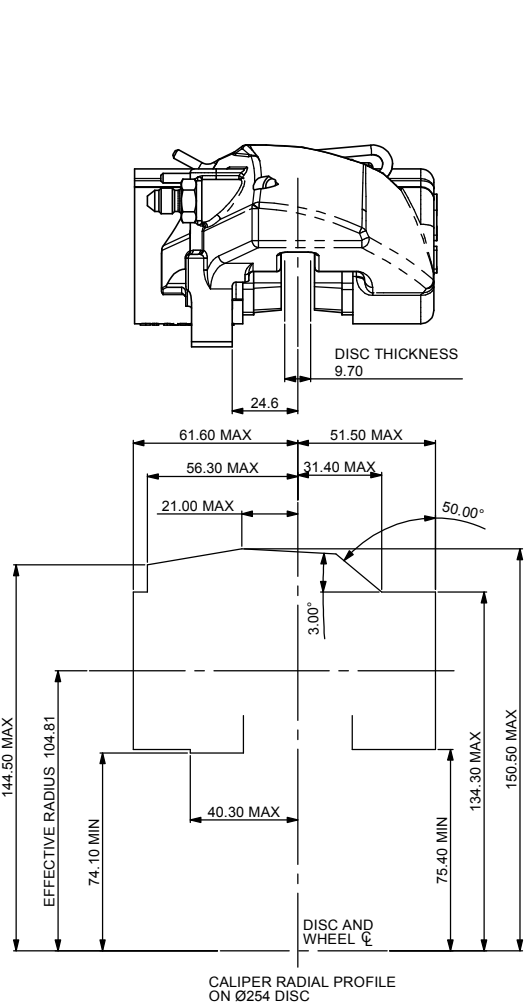

CALIPER RADIAL PROFILE ON Ø254 DISC

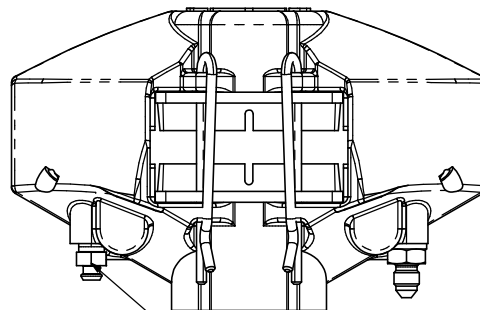
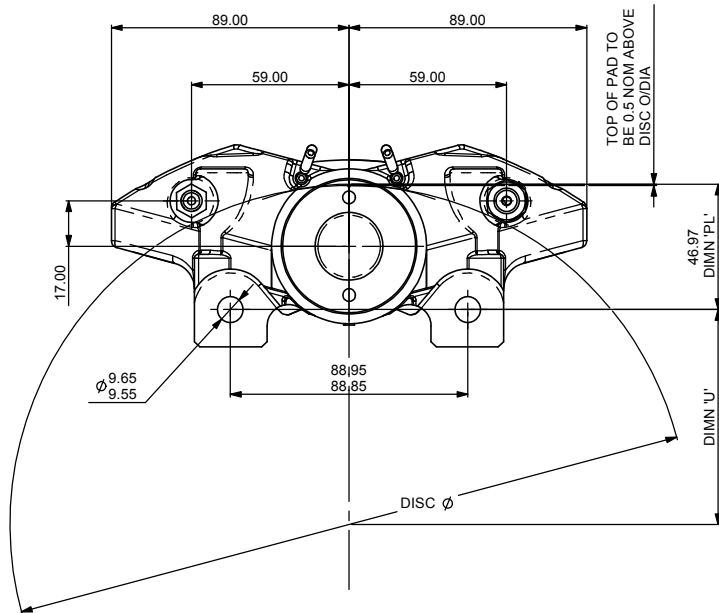

BLEED SCREW TIGHTENING TORQUE 17.0NM (12.5 Lbft)

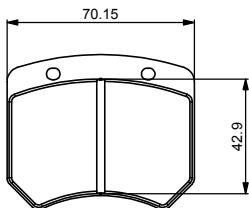

PAD FAMILY CP2399
PAD AREA - 27.38 cm²
PAD VOLUME - 28.75 cm³

GENERAL DESCRIPTION

THIS IS A TWIN OPPOSED BORE ONE PIECE CAST CALIPER DESIGNED TO OPERATE ON A SOLID IRON DISC FROM 10.0" (254.0mm) TO 10.5" (266.7mm). OF THICKNESS 0.38" (9.70mm)

TECHNICAL DATA

PISTON DIA - 2 x 1.625" (41.3mm)
TOTAL PISTON AREA - 4.14 in² (26.76 cm²)
PISTON MATERIAL - ALUMINIUM ALLOY
BODY MATERIAL - ALUMINIUM ALLOY
ALL HYDRAULIC THREADS - 3/8" x 24 UNF

DETAILS

DIMN 'PL' - TOP OF PAD MATERIAL TO MOUNTING HOLE Ø
DIMN 'U' - WHEEL CENTRE TO MOUNTING HOLE Ø
= (DISC DIA/2) + 0.5 - 'PL' DIMN
EFFECTIVE RAD - RADIUS FROM WHEEL Ø TO PISTON Ø

CALIPER PART No.

CP2576-3E0 - UNHANDED CALIPER

INSTALLATION INFORMATION

DISC AND CALIPER MOUNTING TOLERANCES TO BE SUCH THAT THE DISC IS CENTRAL TO THE CALIPER TO WITHIN ±0.5mm

CALIPER IS HANDED BY SWITCHING POSITIONS OF BLEED SCREW AND INLET PORT.
CALIPER TO BE MOUNTED ON ITS SIDE, WITH BLEED SCREW UPPERMOST.

REPLACEMENT SEAL KIT

SEAL KIT (HIGH TEMP) CP4518-K

Issue No.	Alterations		Zone	Initials
	Date & No.	Particulars		
1	09/06/08 B5164	FIRST ISSUE		

SCALE 2:1		SHEET 1 OF 1	
DRAWN	D.ARROWSMITH		
APPROVED			
DERIVED FROM			
TITLE			
2 PISTON CALIPER			
DRG NO.	CP2576-1CD		

A1 INSTALLATION DRAWING

IF THIS DOCUMENT IS PRINTED IN HARDCOPY, IT IS FOR INFORMATION USE ONLY AND THEREFORE IS NOT SUBJECT TO UPDATING CONTROLS. ALWAYS REFER TO SOLIDWORKS VIEWER FOR LATEST ISSUE



THIS DRAWING IS CONFIDENTIAL AND IS SUPPLIED ON THE EXPRESS CONDITION THAT IT SHALL NOT BE LOANED OR COPIED OR DISCLOSED TO ANY OTHER PERSON OR USED FOR ANY OTHER PURPOSE WITHOUT THE WRITTEN CONSENT OF AP RACING LTD.



AP Racing
Wheler Road
Coventry
CV3 4LB

Tel: +44 (0) 24 7663 9595
Fax: +44 (0) 24 7663 9559
e-mail: engineering@apracings.co.uk
Web site: http://www.apracings.com

© AP Racing Ltd. 2005

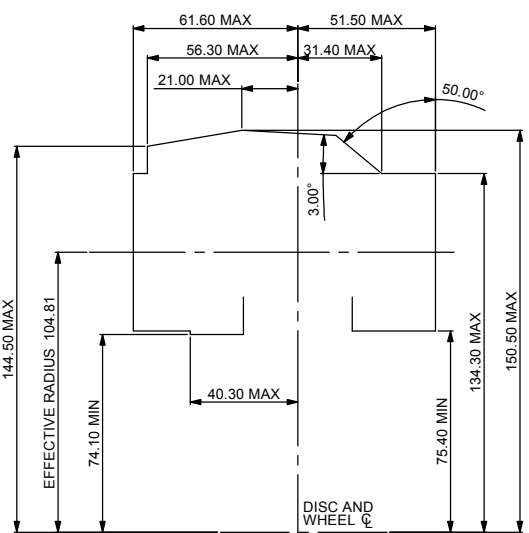
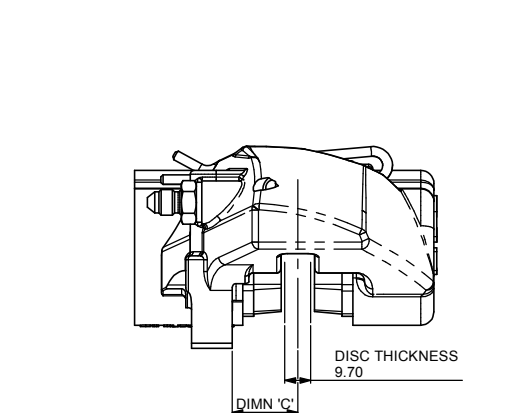

CALIPER RADIAL PROFILE ON $\phi 254$ DISC

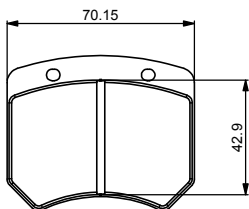

PAD FAMILY CP2399
PAD AREA - 27.38 cm²
PAD VOLUME - 28.75 cm³

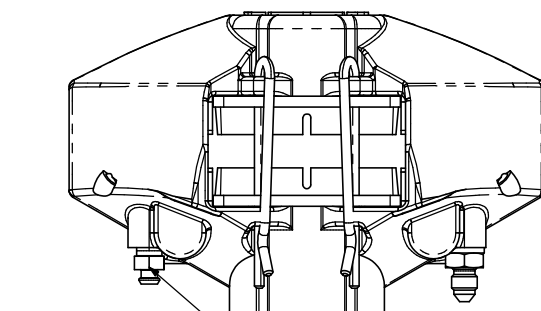
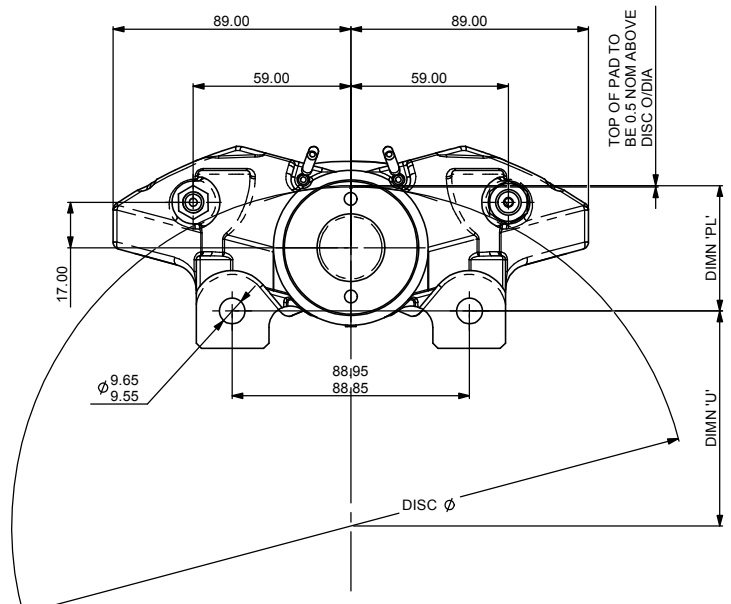

GENERAL DESCRIPTION

THIS IS A TWIN OPPOSED BORE ONE PIECE CAST CALIPER DESIGNED TO OPERATE ON A SOLID IRON DISC FROM 10.0" (254.0mm) TO 10.5" (266.7mm), OF THICKNESS 0.38" (9.70mm)

TECHNICAL DATA

PISTON DIA- 2 x 1.75" (44.5mm)
TOTAL PISTON AREA - 4.81in² (31.04 cm²)
PISTON MATERIAL - ALUMINIUM ALLOY
BODY MATERIAL - ALUMINIUM ALLOY
ALL HYDRAULIC THREADS - 3/8" x 24 UNF

DETAILS

DIMN 'PL' - TOP OF PAD MATERIAL TO MOUNTING HOLE ϕ
DIMN 'U' - WHEEL CENTRE TO MOUNTING HOLE ϕ
= (DISC DIA/2) + 0.5 - 'PL' DIMN
EFFECTIVE RAD - RADIUS FROM WHEEL ϕ TO PISTON ϕ

CALIPER PART No.

CP2577-3E0 - UNHANCED CALIPER

INSTALLATION INFORMATION

DISC AND CALIPER MOUNTING TOLERANCES TO BE SUCH THAT THE DISC IS CENTRAL TO THE CALIPER TO WITHIN ± 0.5 mm

CALIPER IS HANDED BY SWITCHING POSITIONS OF BLEED SCREW AND INLET PORT.
CALIPER TO BE MOUNTED ON ITS SIDE, WITH BLEED SCREW UPPERMOST.

REPLACEMENT SEAL KIT

SEAL KIT (HIGH TEMP) CP4518-L

CALIPER PART No.	OFFSET DIMN 'C'	DIMN 'PL'
CP2577-3E0	24.6	46.97
CP2577-14E0	20.6	49.0

Issue No.	Alterations		Zone	Initials
	Date & No.	Particulars		
1	09/06/08 B5164	FIRST ISSUE		

SCALE 2:1	SHEET 1 OF 1
DRAWN	D.ARROWSMITH
APPROVED	
DERIVED FROM	
TITLE 2 PISTON CALIPER	
DRG NO.	CP2577-1CD

A1 INSTALLATION DRAWING

IF THIS DOCUMENT IS PRINTED IN HARDCOPY, IT IS FOR INFORMATION USE ONLY AND THEREFORE IS NOT SUBJECT TO UPDATING CONTROLS. ALWAYS REFER TO SOLIDWORKS VIEWER FOR LATEST ISSUE



THIS DRAWING IS CONFIDENTIAL AND IS SUPPLIED ON THE EXPRESS CONDITION THAT IT SHALL NOT BE LOANED OR COPIED OR DISCLOSED TO ANY OTHER PERSON OR USED FOR ANY OTHER PURPOSE WITHOUT THE WRITTEN CONSENT OF AP RACING LTD.



AP Racing
Wheler Road
Coventry
CV3 4LB

Tel: +44 (0) 24 7663 9595
Fax: +44 (0) 24 7663 9559
e-mail: engineering@apracings.com
Web site: <http://www.apracing.com>

© AP Racing Ltd. 2005

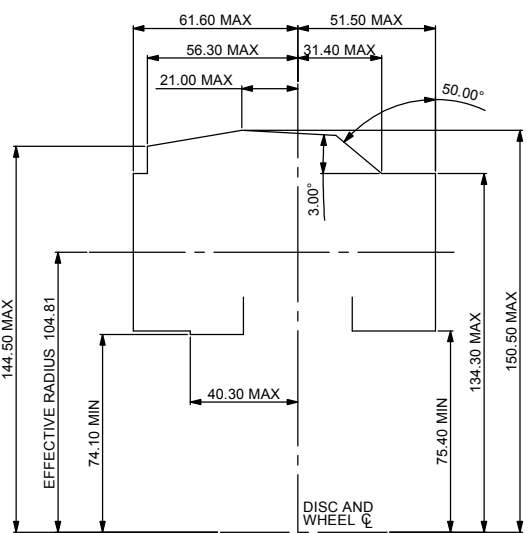
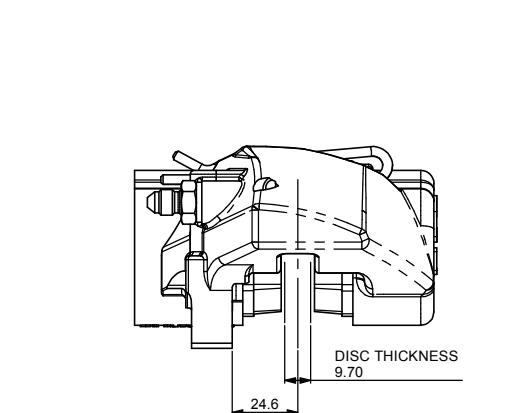

CALIPER RADIAL PROFILE ON $\phi 254$ DISC

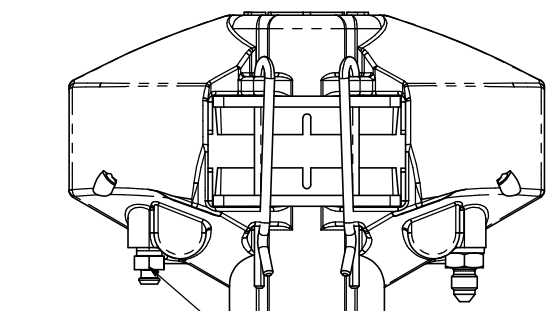
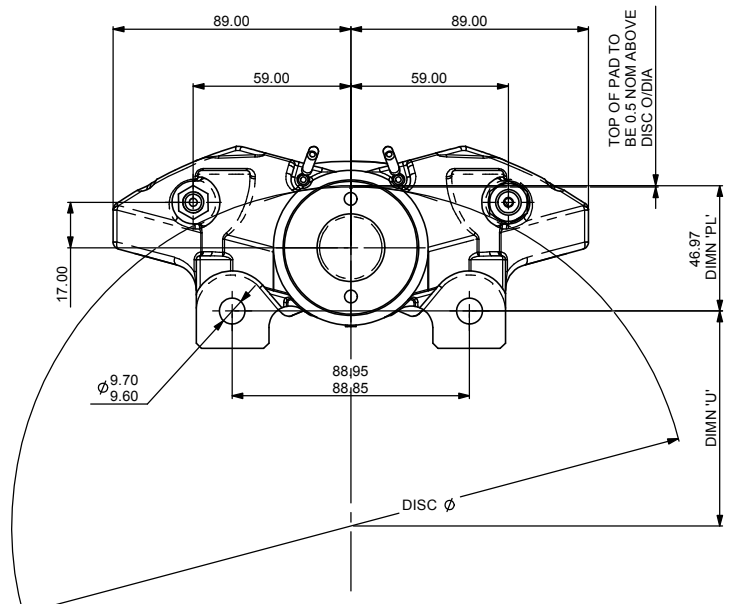

BLEED SCREW TIGHTENING TORQUE 17.0MN (12.5 Lbft)

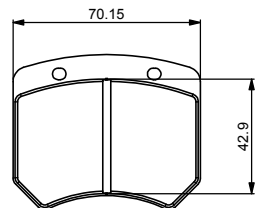

PAD FAMILY CP2399
PAD AREA - 27.38 cm²
PAD VOLUME - 28.75 cm³

GENERAL DESCRIPTION

THIS IS A TWIN OPPOSED BORE ONE PIECE CAST CALIPER DESIGNED TO OPERATE ON A SOLID IRON DISC FROM 10.0" (254.0mm) TO 10.5" (266.7mm), OF THICKNESS 0.38" (9.70mm)

TECHNICAL DATA

PISTON DIA - 2 x 1.5" (38.1mm)
TOTAL PISTON AREA - 3.53 in² (22.80 cm²)
PISTON MATERIAL - ALUMINIUM ALLOY
BODY MATERIAL - ALUMINIUM ALLOY
ALL HYDRAULIC THREADS - 3/8" x 24 UNF

DETAILS

DIMN 'PL' - TOP OF PAD MATERIAL TO MOUNTING HOLE ϕ
DIMN 'U' - WHEEL CENTRE TO MOUNTING HOLE ϕ
= (DISC DIA/2) + 0.5 - 'PL' DIMN
EFFECTIVE RAD - RADIUS FROM WHEEL ϕ TO PISTON ϕ

CALIPER PART No.

CP3176-2E0 - UNHANDED CALIPER

INSTALLATION INFORMATION

DISC AND CALIPER MOUNTING TOLERANCES TO BE SUCH THAT THE DISC IS CENTRAL TO THE CALIPER TO WITHIN ± 0.5 mm

CALIPER IS HANDED BY SWITCHING POSITIONS OF BLEED SCREW AND INLET PORT.
CALIPER TO BE MOUNTED ON ITS SIDE, WITH BLEED SCREW UPPERMOST.

REPLACEMENT SEAL KIT

SEAL KIT (HIGH TEMP) CP4518-J

Issue No.	Alterations		Zone	Initials
	Date & No.	Particulars		
1	09/06/08 B5164	FIRST ISSUE		

SCALE 2:1	SHEET 1 OF 1
DRAWN	D.ARROWSMITH
APPROVED	
DERIVED FROM	
TITLE 2 PISTON CALIPER	
DRG NO.	CP3176-1CD

A1 INSTALLATION DRAWING

IF THIS DOCUMENT IS PRINTED IN HARDCOPY, IT IS FOR INFORMATION USE ONLY AND THEREFORE IS NOT SUBJECT TO UPDATING CONTROLS. ALWAYS REFER TO SOLIDWORKS VIEWER FOR LATEST ISSUE



THIS DRAWING IS CONFIDENTIAL AND IS SUPPLIED ON THE EXPRESS CONDITION THAT IT SHALL NOT BE LOANED OR COPIED OR DISCLOSED TO ANY OTHER PERSON OR USED FOR ANY OTHER PURPOSE WITHOUT THE WRITTEN CONSENT OF AP RACING LTD.



AP Racing
Wheler Road
Coventry
CV3 4LB

Tel: +44 (0) 24 7663 9595
Fax: +44 (0) 24 7663 9559
e-mail: engineering@apracings.com
Web site: <http://www.apracings.com>

© AP Racing Ltd. 2005

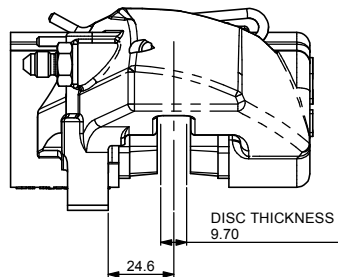

DISC THICKNESS
9.70

24.6

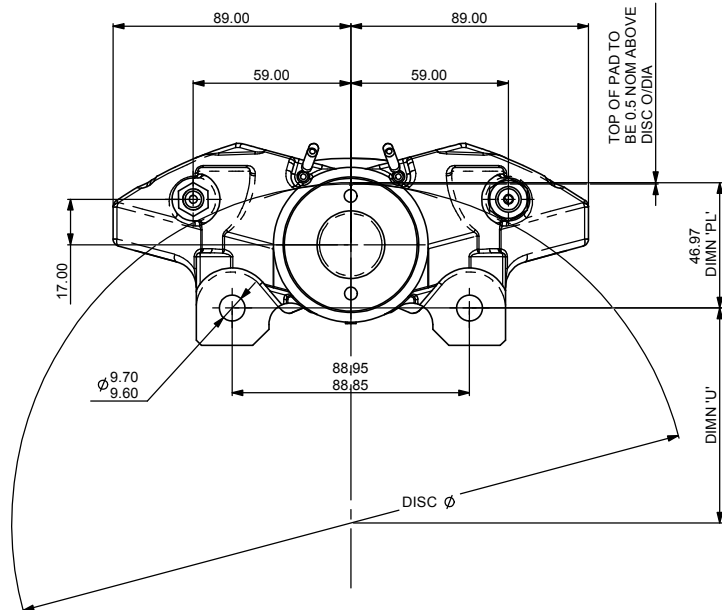

TOP OF PAD TO
BE 0.5 NOM ABOVE
DISC O/DIA

GENERAL DESCRIPTION

THIS IS A TWIN OPPOSED BORE ONE PIECE CAST CALIPER DESIGNED TO OPERATE ON A SOLID IRON DISC FROM 10.0" (254.0mm) TO 10.5" (266.7mm). OF THICKNESS 0.38" (9.70mm)

TECHNICAL DATA

PISTON DIA - 2 x 36.0mm
TOTAL PISTON AREA - 20.35 cm²
PISTON MATERIAL - ALUMINIUM ALLOY
BODY MATERIAL - ALUMINIUM ALLOY
ALL HYDRAULIC THREADS - 3/8" x 24 UNF

DETAILS

DIMN 'PL' - TOP OF PAD MATERIAL TO MOUNTING HOLE ϕ
DIMN 'U' - WHEEL CENTRE TO MOUNTING HOLE ϕ
= (DISC DIA/2) + 0.5 - 'PL' DIMN
EFFECTIVE RAD - RADIUS FROM WHEEL ϕ TO PISTON ϕ

CALIPER PART No.

CP3177-2E0 - UNHANDED CALIPER

INSTALLATION INFORMATION

DISC AND CALIPER MOUNTING TOLERANCES TO BE SUCH THAT THE DISC IS CENTRAL TO THE CALIPER TO WITHIN ± 0.5 mm

CALIPER IS HANDED BY SWITCHING POSITIONS OF BLEED SCREW AND INLET PORT
CALIPER TO BE MOUNTED ON ITS SIDE, WITH BLEED SCREW UPPERMOST.

REPLACEMENT SEAL KIT

SEAL KIT (HIGH TEMP) CP4518-H

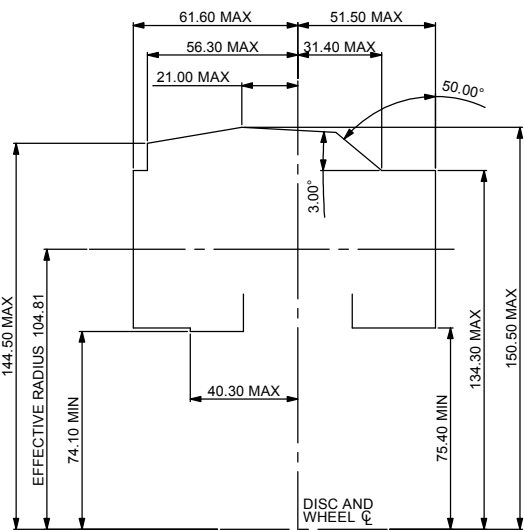

CALIPER RADIAL PROFILE
ON Ø254 DISC

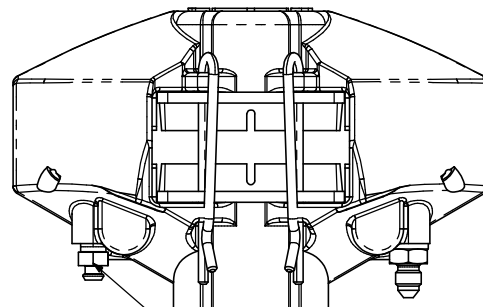

BLEED SCREW TIGHTENING
TORQUE 17.0NM (12.5 Lbft)

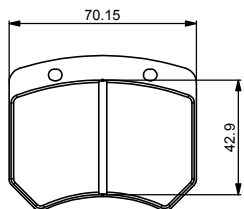

PAD FAMILY CP2399

PAD AREA - 27.38 cm²
PAD VOLUME - 28.75 cm³

Issue No.	Alterations		Zone	Initials
	Date & No.	Particulars		
1	09/06/08 B5164	FIRST ISSUE		

SCALE 2:1	SHEET 1 OF 1
DRAWN	D.ARROWSMITH
APPROVED	
DERIVED FROM	
TITLE 2 PISTON CALIPER	
DRG NO.	CP3177-1CD

A1 INSTALLATION DRAWING

IF THIS DOCUMENT IS PRINTED IN HARDCOPY, IT IS FOR INFORMATION USE ONLY AND THEREFORE IS NOT SUBJECT TO UPDATING CONTROLS. ALWAYS REFER TO SOLIDWORKS VIEWER FOR LATEST ISSUE



THIS DRAWING IS CONFIDENTIAL AND IS SUPPLIED ON THE EXPRESS CONDITION THAT IT SHALL NOT BE LOANED OR COPIED OR DISCLOSED TO ANY OTHER PERSON OR USED FOR ANY OTHER PURPOSE WITHOUT THE WRITTEN CONSENT OF AP RACING LTD.



AP Racing
Wheler Road
Coventry
CV3 4LB

Tel: +44 (0) 24 7663 9595
Fax: +44 (0) 24 7663 9559
e-mail: engineering@apracings.co.uk
Web site: <http://www.apracings.com>

© AP Racing Ltd. 2005

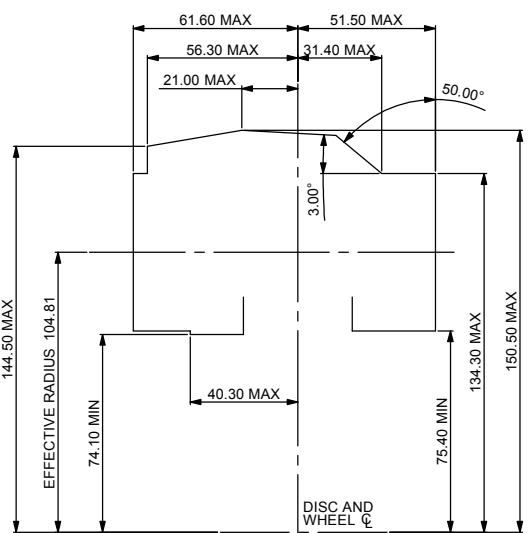
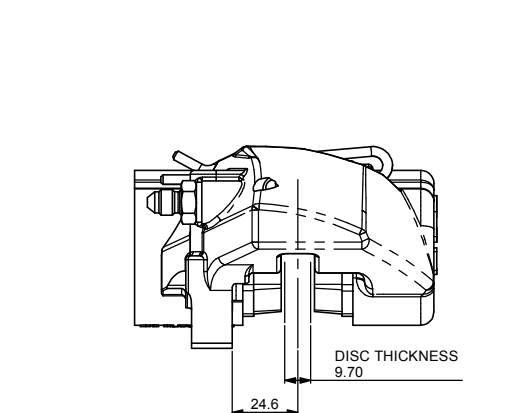

CALIPER RADIAL PROFILE ON $\phi 254$ DISC

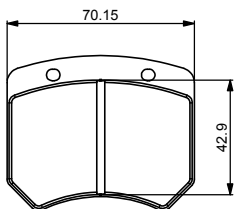

PAD FAMILY CP2399

PAD AREA - 27.38 cm²
PAD VOLUME - 28.75 cm³

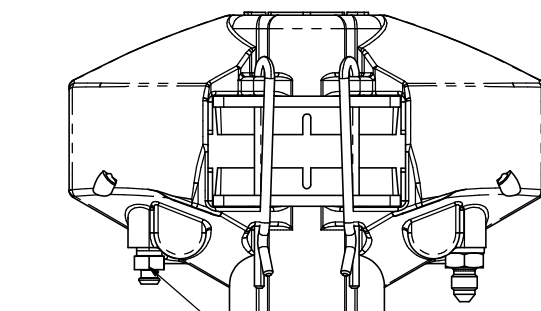
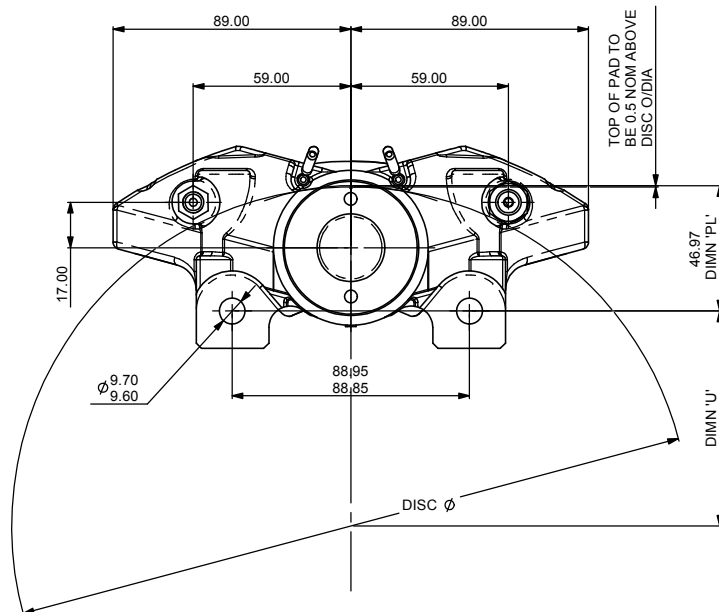

GENERAL DESCRIPTION

THIS IS A TWIN OPPOSED BORE ONE PIECE CAST CALIPER DESIGNED TO OPERATE ON A SOLID IRON DISC FROM 10.0" (254.0mm) TO 10.5" (266.7mm). OF THICKNESS 0.38" (9.70mm)

TECHNICAL DATA

PISTON DIA- 2 x 1.25" (31.75mm)
TOTAL PISTON AREA- 2.45 in² (15.83 cm²)
PISTON MATERIAL - ALUMINIUM ALLOY
BODY MATERIAL - ALUMINIUM ALLOY
ALL HYDRAULIC THREADS - 3/8" x 24 UNF

DETAILS

DIMN 'PL' - TOP OF PAD MATERIAL TO MOUNTING HOLE ϕ
DIMN 'U' - WHEEL CENTRE TO MOUNTING HOLE ϕ
= (DISC DIA/2) + 0.5 - 'PL' DIMN
EFFECTIVE RAD - RADIUS FROM WHEEL ϕ TO PISTON ϕ

CALIPER PART No.

CP3178-2E0 - UNHANDED CALIPER

INSTALLATION INFORMATION

DISC AND CALIPER MOUNTING TOLERANCES TO BE SUCH THAT THE DISC IS CENTRAL TO THE CALIPER TO WITHIN ± 0.5 mm

CALIPER IS HANDED BY SWITCHING POSITIONS OF BLEED SCREW AND INLET PORT.
CALIPER TO BE MOUNTED ON ITS SIDE, WITH BLEED SCREW UPPERMOST.

REPLACEMENT SEAL KIT

SEAL KIT (HIGH TEMP) CP4518-E

Issue No.	Alterations		Zone	Initials
	Date & No.	Particulars		
1	09/06/08 B5164	FIRST ISSUE		

SCALE 2:1	SHEET 1 OF 1
DRAWN	D.ARROWSMITH
APPROVED	
DERIVED FROM	
TITLE 2 PISTON CALIPER	
DRG NO.	CP3178-1CD