

# A1 INSTALLATION DRAWING

IF THIS DOCUMENT IS PRINTED IN HARDCOPY, IT IS FOR INFORMATION USE ONLY AND THEREFORE IS NOT SUBJECT TO UPDATING CONTROLS. ALWAYS REFER TO SOLIDWORKS VIEWER FOR LATEST ISSUE



FIRST ANGLE PROJECTION

THIS DRAWING IS CONFIDENTIAL AND IS SUPPLIED ON THE EXPRESS CONDITION THAT IT SHALL NOT BE LOANED OR COPIED OR DISCLOSED TO ANY OTHER PERSON OR USED FOR ANY OTHER PURPOSE WITHOUT THE WRITTEN CONSENT OF AP RACING LTD.



AP Racing  
Wheler Road  
Coventry  
CV3 4LB

Tel: +44 (0)24 7663 9595  
Fax: +44 (0)24 7663 9599  
e-mail: [engineering@apracings.co.uk](mailto:engineering@apracings.co.uk)  
Web site: <http://www.apracings.com>

© AP Racing Ltd. 2005

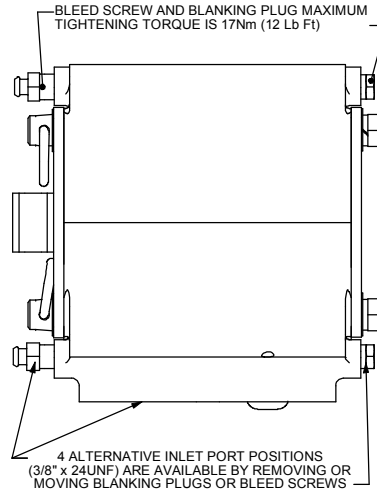
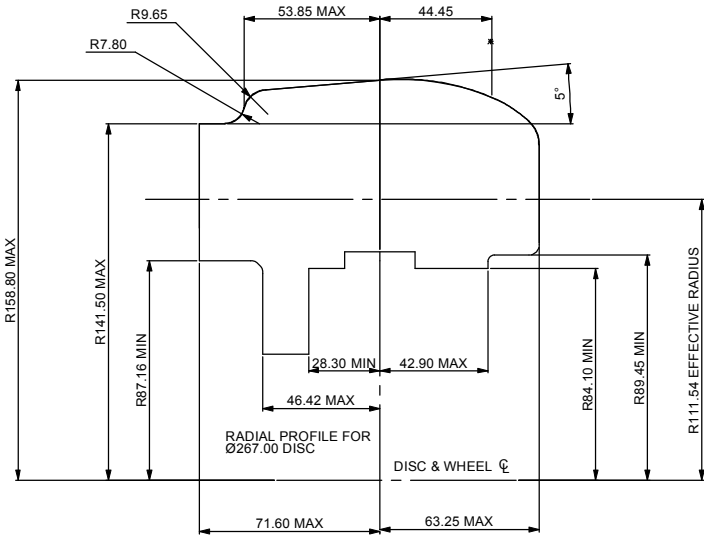
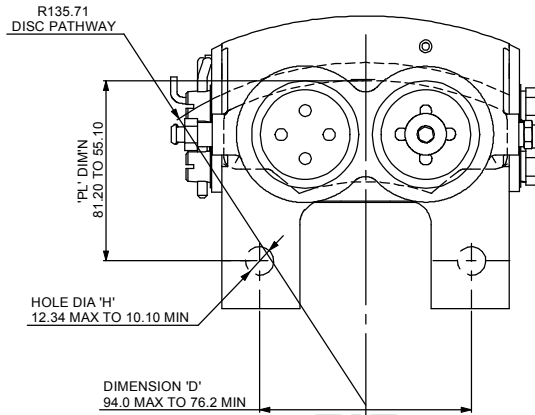
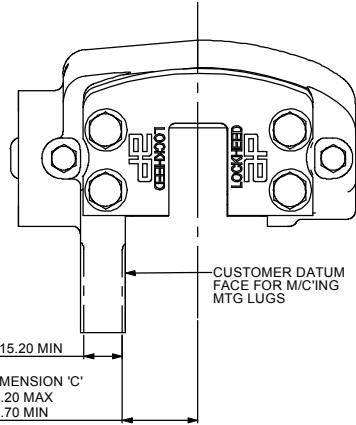

**GENERAL DESCRIPTION:**

THIS IS A 4 PISTON CLOSED BLOCK CALIPER WITH BLANK MOUNTING LUGS. THE MOUNTING LUGS MAY BE MACHINED WITHIN THE PARAMETERS GIVEN. IT IS DESIGNED TO OPERATE ON A CAST IRON DISC 0245.0 - 0257.0 x 20.7 THICK.

QUICK RELEASE END PLATES ARE AVAILABLE TO ENABLE RAPID PAD REPLACEMENT SEALS ARE HIGH TEMPERATURE SEAL-IN-BORE TYPE.

**TYPICAL APPLICATION:**

HISTORIC SPORTS CARS & RALLY

**TECHNICAL INFORMATION:**

TOTAL PISTON AREA: 45.60cm<sup>2</sup>  
PISTON MATERIAL: ALUMINIUM ALLOY  
BODY MATERIAL: ALUMINIUM ALLOY  
ALL HYDRAULIC CONNECTIONS: 3/8" x 24UNF  
PISTON ANTI-KNOCK BACK SPRINGS (4LB) FITTED  
ASSEMBLY WEIGHT: 2.0 Kg. ( WITHOUT PADS )

**INSTALLATION INFORMATION:**

DISC & CALIPER MOUNTING TOLERANCES TO BE SUCH THAT THE DISC IS CENTRAL TO THE CALIPER TO WITHIN  $\pm$ 0.5mm.

**KEY TO DIMENSIONS:**

DIMENSION PL: TOP OF PAD MATERIAL TO MOUNTING HOLE CENTRE LINE WITH PAD SITTING DOWN ON LEDGE. TO BE SET BY THE CUSTOMER WITHIN THE PARAMETERS GIVEN.

DIMENSION U: WHEEL CENTRE LINE TO CALIPER MOUNTING HOLE CENTRE LINE. DETERMINED USING THE FOLLOWING FORMULA.

$$(DISC DIA / 2) + 0.5 - DIMENSION PL \cdot (UNITS mm).$$

THIS FORMULA APPLIES TO DISCS UP TO  $\phi$ 302.0 FOR DISCS LARGER THAN THIS IT MAY BE NECESSARY TO INCREASE THE PAD OVERLAP TO GREATER THAN THE 0.5mm IN THE FORMULA. THE CRITERIA WILL BE TO ENSURE THE DISC IS RADIIALLY CLEAR OF THE END PLATE SLOT BY 2.0mm MINIMUM.

DIMENSION C: OFFSET. DISC CENTRE LINE TO MOUNTING FACE. TO BE SET BY THE CUSTOMER WITHIN THE PARAMETERS GIVEN.

AP RACING TECHNICAL SECTION WILL BE PLEASED TO ADVISE ON THE MOST SUITABLE EQUIPMENT FOR ANY PARTICULAR APPLICATION.

**PART NUMBERS:**

CP2361-96S4QR - RIGHT HAND ASSEMBLY  
CP2361-97S4QR - LEFT HAND ASSEMBLY

**REPLACEMENT SEAL KIT:**

SEAL KIT (HIGH TEMPERATURE) CP4518-JJ

CALIPER IS HANDED BY THE POSITION OF THE CROSS DRILLING. THE BLEED SCREWS ARE FITTED TO THE OPPOSITE END TO THE CROSS DRILLING AND SHOULD BE UPPERMOST ON INSTALLATION

RH CALIPER IS SHOWN

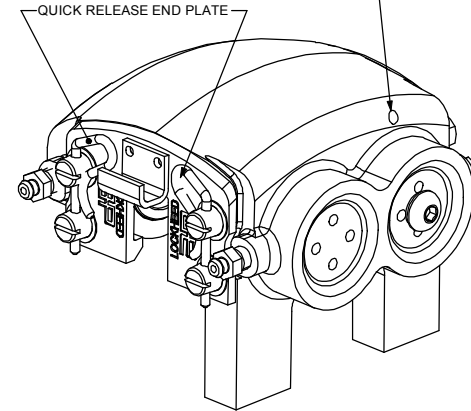

**PAD FAMILY CP2340D43**

PAD AREA:  
- SLOTTED : 40.14 cm<sup>2</sup>  
- FULL AREA : 41.54 cm<sup>2</sup>

PAD VOLUME:  
- SLOTTED : 46.16 cm<sup>3</sup>  
- FULL AREA : 47.77 cm<sup>3</sup>

**PAD FAMILY CP2340D51**

PAD AREA:  
- SLOTTED : 43.36cm<sup>2</sup>  
- FULL AREA : 45.04cm<sup>2</sup>

PAD VOLUME:  
- SLOTTED : 49.86cm<sup>3</sup>  
- FULL AREA : 51.79cm<sup>3</sup>

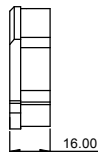

Issue No.	Alterations		Zone	Initials
	Date & No.	Particulars		
1	29/01/09 B5444	FIRST ISSUE		SA

SCALE 1:1	SHEET 1 OF 1
DRAWN	Steve Thomas
APPROVED	
DERIVED FROM	
TITLE	
INSTALLATION OF 4 x 1.50" CLOSED BLOCK CALIPER	
DRG NO.	CP2361-1CD