

PUBLICATION P12.147

ISSUE 2

If this document is printed in hardcopy, it is for information use only and therefore is not subject to updating controls. Always refer to viewer for latest issue.

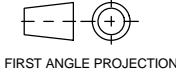

THIS DRAWING IS CONFIDENTIAL AND IS SUPPLIED ON THE EXPRESS CONDITION THAT IT SHALL NOT BE LOANED OR COPIED OR DISCLOSED TO ANY OTHER PERSON OR USED FOR ANY OTHER PURPOSE WITHOUT THE WRITTEN CONSENT OF AP RACING LTD.



© AP Racing Ltd. 2000

AP Racing
Wheler Road
Coventry
CV3 4LB

Tel: +44 024 7663 9595 e-mail: sales@apracing.co.uk
Fax: +44 024 7663 9559 Web site: HTTP://www.apracing.com

BMW E36 M3 REAR
KIT NUMBER CP5144-1002/R2/NRJ

Ref	Part #	Description	QTY
	CP5144-18S4	Caliper Right Hand	1
1	CP5144-19S4	Caliper Left Hand	1
2	CP2340D43-DS2500	Pad Set	1
3	CP5100-151	Anti-Rattle Clip	2
4	CP3758-101	Banjo Bolt	2
5	CP4695-121	Banjo	2
6	CP4520-120	Mounting Bolt	4
7	CP2494-853	Mounting Nut	4
8	CP5200-150	Washer	4
9	KL44517	Gasket	4
10	CP5100-120ST	Retainer Bolt	2

Left hand shown

Right hand opposite

Tightening Torques

Part Ref #	Torque
Bolt & Nut Ref 7 & 8	58NM
Banjo to Hose	30NM
Bolt Ref 4	25NM
Caliper Bleed Screw	17NM
Bolt Ref 11	13NM

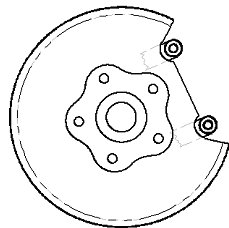
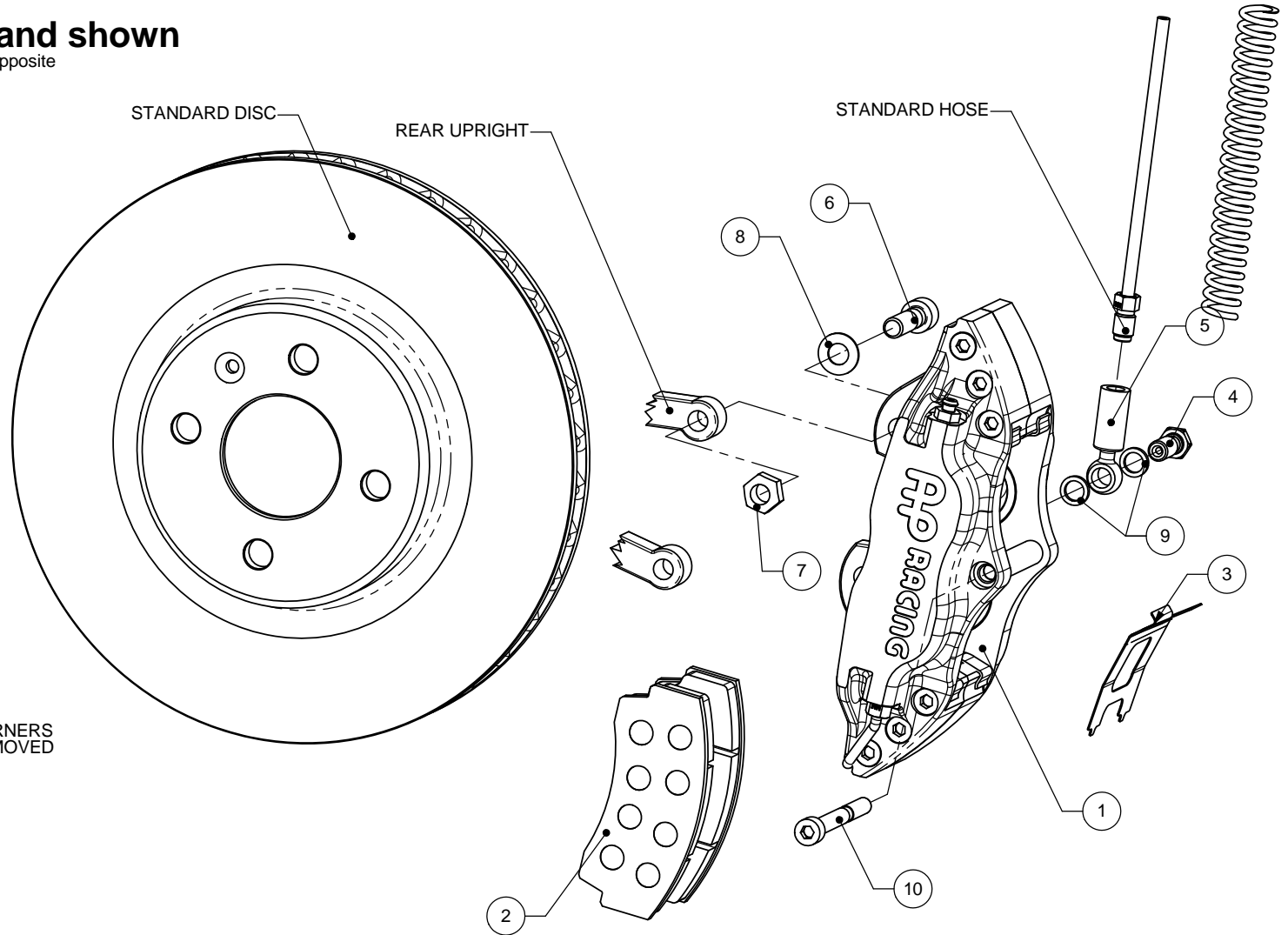

SPLASH GUARD BEFORE MODIFICATION

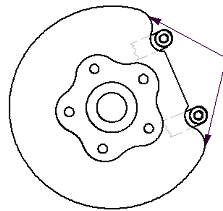

SPLASH GUARD AFTER MODIFICATION

CORNERS REMOVED

MODIFY SPLASH GUARD BY REMOVING THE CORNERS AS SHOWN IN THE DIAGRAM ABOVE TO ALLOW CLEARANCE FOR LARGER CALIPER.

PLEASE RETAIN THIS SHEET FOR FUTURE REFERENCE

THIS IS A PICTORIAL VIEW FOR REFERENCE ONLY. SOME PARTS MAY VARY FROM THOSE SUPPLIED. AP RACING RESERVE THE RIGHT TO CHANGE COMPONENTS WITHOUT PRIOR NOTICE

DRAWN : Joe Hartog