

PUBLICATION P12.108

ISSUE : 2

If this document is printed in hardcopy, it is for information use only and therefore is not subject to updating controls. Always refer to viewer for latest issue.

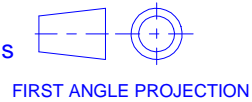

THIS DRAWING IS CONFIDENTIAL AND IS SUPPLIED ON THE EXPRESS CONDITION THAT IT SHALL NOT BE LOANED OR COPIED OR DISCLOSED TO ANY OTHER PERSON OR USED FOR ANY OTHER PURPOSE WITHOUT THE WRITTEN CONSENT OF AP RACING LTD.



© AP Racing Ltd. 2000
AP Racing
Wheler Road
Coventry
CV3 4LB

Tel: +44 024 7663 9595 e-mail: sales@apracing.co.uk
Fax: +44 024 7663 9559 Web site: HTTP://www.apracing.com

BMW E46 318/325i KIT NUMBER CP5570-1011 17"		
Ref	Description	QTY
1	Caliper Right Hand	1
	Caliper Left Hand	1
2	Disc Right Hand	1
	Disc Left Hand	1
3	Mounting Bell	2
4	Mounting Bracket LH/RH	2
5	Pad Set	1
6	Bracket Mtg Bolt	4
7	Cleavloc Nut	4
8	Caliper Mtg Bolt	4
9	Washer	4
10	Disc Mtg Bolt	24
11	Washer	24
12	Disc Mtg Nut	24
13	Hose Kit	1
14	Banjo	2
15	Gasket	4
16	0.5mm Shim	12
17	Pad Retainer Bolt	4
18	Nylon Armouring	2
19	Anti-Rattle Clip	2
20	Washer	8
21		
22		
23		
24		
25		

Tightening Torques	
Part Ref #	Torque
Bolt/Nut Ref 6/7	68NM
Bolt Ref 8	58NM
Bolt Ref 10	14NM
Bolt Ref 17	13NM
Banjo Bolt Ref 14	25NM
Caliper Bleed Screw	17NM

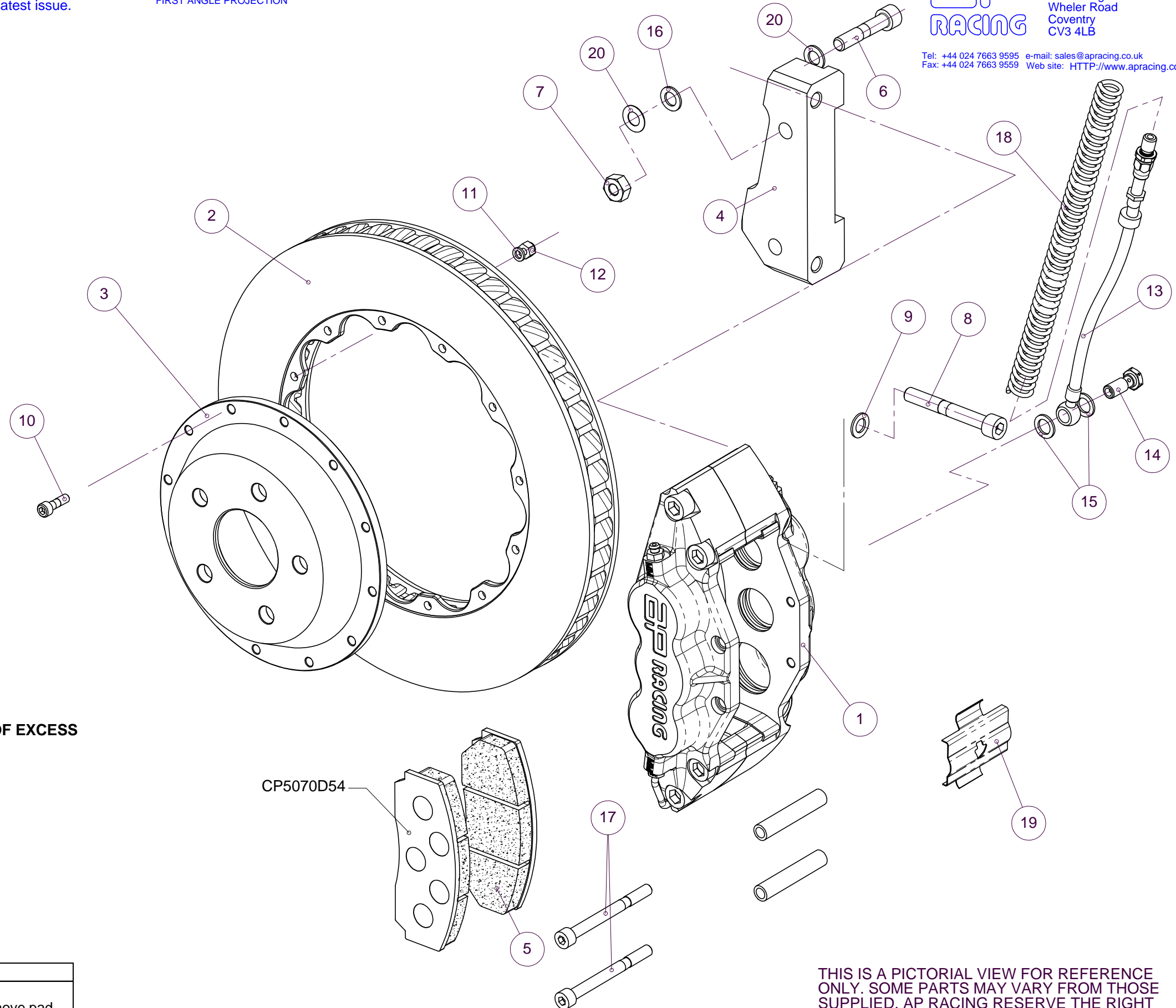

IT MAY BE NECESSARY TO REMOVE A SMALL AMOUNT OF EXCESS MATERIAL FROM THE UPPER CALIPER LUG MOUNTING

CP5070D54

BRAKE DISC WEAR	
NEW	MIN WORN
28.00mm	27.00mm

Comments
Cut away bottom corner of splash guard to miss the bracket. Remove pad retainer bolt ref 17 to fit anti-rattle clip part ref 19 and retighten to specified torque.

PLEASE RETAIN THIS SHEET FOR FUTURE REFERENCE

THIS IS A PICTORIAL VIEW FOR REFERENCE ONLY. SOME PARTS MAY VARY FROM THOSE SUPPLIED. AP RACING RESERVE THE RIGHT TO CHANGE COMPONENTS WITHOUT PRIOR NOTICE.

DRAWN : astrachan