

BRAKE DISCS



- ▣ GENERAL INFORMATION.
 - ▣ VENTILATED DISCS.
 - ▣ SOLID DISCS.
- ▣ VENTILATED DISCS WITH INTEGRAL MOUNTING BELL.
 - ▣ VENTILATED DISC, BELL AND PAD KITS.
- ▣ SOLID DISCS WITH INTEGRAL MOUNTING BELL.
 - ▣ TEMPERATURE MEASUREMENT TOOLS.
 - ▣ CARBON/CARBON DISCS.

BRAKE DISCS - General Information

INTRODUCTION.

The AP Racing range of ventilated and solid brake discs have been developed with the benefit of unparalleled experience in brake technology, to meet the severe demands encountered under Race, Rally and Road conditions.

RACE: Our extensive range includes discs to suit all of the most demanding series in the world. Teams competing in F3, WRC, GT and Sports Prototypes, Nascar and Touring Car Championships use AP Racing discs.

ROAD: As well as our successes on the circuits and stages of the world, AP Racing has developed disc braking systems for many leading volume and specialist High Performance vehicle manufacturers including Aston Martin, Bugatti, Caterham, Ford, HSV, Koenigsegg, Morgan, Lotus, Seat and TVR, to name a few.

DESIGN.

AP Racing share innovations in the R&D processes between Race and Road projects, the basic function is the same for both although each has different service requirements.

▣ **Race Discs** are submitted to high braking and thermal loads. These loads are repeated frequently over many laps or stages.

The service life is short and noise and comfort are not really an issue. Race discs normally employ a separate disc and bell assembly which are generally available in two types:

- **Light Duty - 2 piece bolted assemblies.**
- **Heavy Duty - 2 piece floating assemblies.**

A given disc has to fit many different customer cars, so they require custom mounting bells.

▣ **Road Discs** however have relatively low and infrequent loads, although mass increases compared to race cars which generates high braking torques. Road Discs have comfort and long service life requirements. Costs of each item also have to remain low for the OEM and the end user when replacement time arrives. For road cars, many applications use 1 piece disc and bell assemblies, this is due to high volume production requirements. High performance vehicles and Big Brake Kits usually use 2 piece bolted assemblies, enabling to fit a heavy duty closer to race than road disc.

- **Light Duty - 1 piece disc and bell assembly.**
- **Heavy Duty - 2 piece bolted assemblies.**

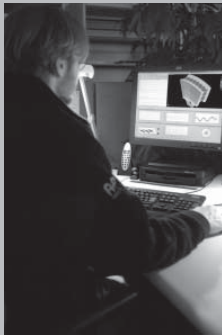

RESEARCH AND DEVELOPMENT.

Over the last nine years AP Racing has placed increased emphasis on advanced research and simulation to complement the existing technology, test and manufacturing processes of our competition and road discs. Product improvement is continuous, using feedback from our state of the art dynamometer and track testing AP Racing are able to offer brake discs with optimum performance and cooling characteristics for any application.

- DEVELOPMENT TOOLS.

AP Racing is equipped with state of the art design tools which have enabled us to study disc performance to a level not hitherto possible.

FEA: CFD AND THERMAL STRESS ANALYSIS.

Thermal simulation enables assessment of brake disc cooling without having to build costly prototypes. AP Racing has reached a high degree of confidence using these methods and has adopted FEA as the base of our design process, this enables AP Racing to tailor disc design to a given application.

- R&D EXAMPLES.

The latest example of how our disc development department has benefited the AP Racing disc range.

- SINUSOIDAL ('S' VANE) DISC CASTING

A Sinusoidal Vane cast iron disc has been developed for Nascar, with others due to follow in Touring Car, GT and Rally Car applications.

Utilising the development tools available our R&D department were able to design a new casting to run between 70-100°C cooler than the old designs, the new 'S' Vane disc provides a significant improvement in brake performance, wear rate and reliability.

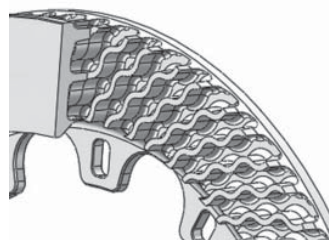

- DYNAMOMETER TESTING.

Not everything can be modelled yet, so validation testing is essential. Our proven dynamometer, has been supplemented by a second, more powerful machine equipped with state of the art features. Two fully operational dyno's give us even more significant test capabilities and help us demonstrate that AP Racing brake discs are the best.

AP Racing dynamometer plots provide data examples such as temperature and Friction Co-efficient comparison.

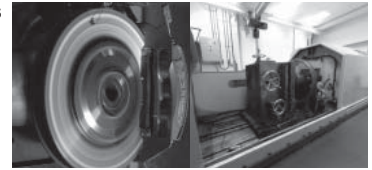

NUMERICAL SIMULATION.

AP Racing has continued to develop a unique thermal simulation software, in order to predict overall brake system temperatures on a real life cycle. This simulation is particularly useful for selection of brake specifications, and wear predictions for endurance races. It is able to calculate bulk temperatures and compare different brake system solutions for various vehicles and race tracks.

DISC CHOICE.

The choice of a particular size and type of disc will depend on the characteristics of the vehicle. Experience with the type of installation or racing format is very important. AP Racing has a wealth of experience of all types of racing and our Technical Section will be pleased to advise on disc choice. Some of the main considerations in this choice are:

HOMOLOGATION AND REGULATION.

In Group A and certain other classes of racing, brake equipment is restricted to that Homologated by the manufacturer with the FIA. Where applicable you must therefore choose a disc size / type which has been Homologated. E.g. only 4 grooves are allowed in Formula 3.

DISC DIAMETER AND THICKNESS.

Disc diameter and thickness are major factors in basic stopping power. Usually the largest diameter disc that can be installed in a particular wheel profile is chosen to maximise braking power unless low weight, poor tyre adhesion or required brake balance dictate otherwise. Disc thicknesses normally increase with disc diameter and in proportion to vehicle weight and hence work done and cooling required. Standard disc sizes should be used wherever possible as this improves availability.

DISC RUBBING DEPTHS (SWEEP DEPTH).

It is important to match the swept area of the disc to the Pad / Caliper combination that is intended to be used, to avoid any large cold areas which could lead to disc distortion. To make this easier the radial depth of all AP Racing brake pads is incorporated into the part number (the "D" Number e.g. D46, D50 & D54).

Normally the Pad / Caliper is positioned so that the top edge of the pad is level with the nominal disc outside diameter. However it is normal to make the eye diameter on the inboard face (Non mounting side) slightly smaller in diameter than the mounting side to match the thermal characteristics of the two disc faces and avoid distortion in use. The amount of this under-hang will vary according to the installation and is part of the disc designers art, but analysis carried out by AP Racing shows that 2mm radius (4mm on diameter) is sufficient in most cases.

N.B. THE PAD SHOULD NEVER OVERHANG THE DISC AS THIS WILL LEAD TO A NUMBER OF BRAKING DIFFICULTIES.

DISC HANDING.

RIGHT / LEFT HAND IDENTIFICATION

Most AP Racing brake discs feature curved vanes and are handed. They should be installed with the cooling vanes running back from the inside to outside diameters in the direction of rotation as indicated in the sketch.

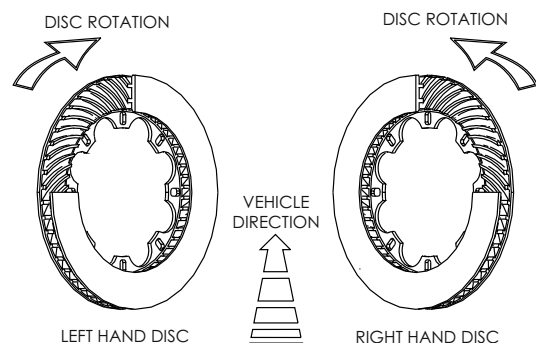

BRAKE DISCS - Ventilated Discs - Ø254mm to Ø295mm

DISC LISTINGS.

The variety of disc options available provide the solution for virtually every Racing and High Performance Road application. The discs illustrated in these sections are a selection of discs from the range and have been listed by diameter, thickness and mounting details for convenience. If you are unable to satisfy your requirements from the discs listed then please contact AP Racing Technical Section for guidance.

VENTILATED BRAKE DISCS.

This section on ventilated brake discs provides dimensional details, as well as information on face types and the weight of the most popular discs from the AP Racing disc range. **Not all discs are listed**, should you require a disc with particular dimensions which is not listed please contact the AP Racing Technical Section for assistance.

Discs which are highlighted are from the preferred disc range, which offers improved availability and pricing. Please contact AP Racing if you require more information.

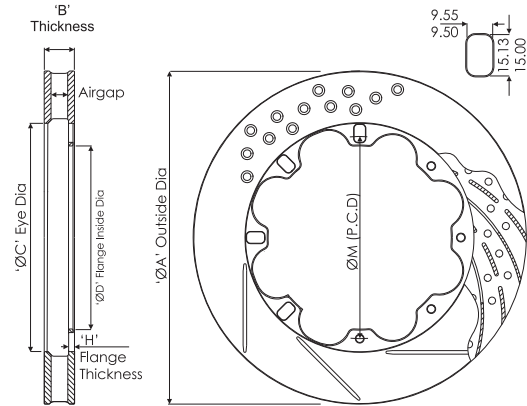

Nominal Dimensions in (mm)														Max Pad Depth.	No. of Vanes.	Air Gap.	Weight Kg.	Face Types Available.	Comments.	Part Numbers.
'A' Outside Dia.	'B' Thickness	'M' P.C.D.	No.	Fixing Type. S/Bobbin = Standard CP2494. H/Bobbin = Heavy Duty CP4135 or CP7016	Ø.	'C' (Eye) Ø.	'D' Inside Flange Ø.	'H' Mtg. Flange												
254.0	21.0	139.7	6	Bolted	6.4	154.9	125.8	5.6	D46	36	9.3	3.2	G4		CP4136-568					
257.0	21.0	139.7	6	Bolted	6.4	154.9	125.8	5.6	D51	36	9.3	3.6	G4		CP4136-86					
260.0	25.4	139.7	6	Bolted	6.4	154.9	125.8	4.8	D51	48	10.5		G4	Mtg flange stepped in 1.2mm	CP4448-226/7					
262.0	20.7	145.0	8	Bolted	6.4	158.0	130.0	5.3	D51	36	9.3	3.5	G4		CP4136-888					
263.0	17.0	152.0	8	S/Bobbin	/	174.6	128.0	4.325	D43	47	8.0	2.44	CG4	Bobbin CP2494-595MA	CP3947-110/1					
	18.0	152.0	8	Bolted	6.4	174.6	136.0	4.3	D43	47	8.0	2.6	CG4	Mtg flange stepped out 0.1mm	CP3947-108/9					
264.0	21.0	139.7	6	Bolted	6.4	154.9	125.8	5.6	D51	36	9.3	3.7	G4		CP4136-208					
265.0	17.0	139.7	8	Bolted	6.4	162.7	123.0	4.82	D51	24	6.5	3.0	G8		CP3770-1026/7					
267.0	16.0	162.0	8	Bolted	6.4	180.7	145.0	4.35	D43	24	6.5		CG4		CP3770-1016/7					
	18.0	158.0	8	Bolted	6.4	172.6	140.0	5.375	D46	24	6.5	3.1	CG4		CP3770-1030/1					
	20.0	152.0	8	Bolted	6.4	172.6	138.0	4.82	D46	36	9.3	3.2	G4		CP4136-924					
	21.0	139.7	6	Bolted	6.4	155.0	125.8	5.6	D54	36	9.3	4.4	G4		CP4136-48					
	25.4	139.7	6	Bolted	6.4	180.2	123.0	5.02	D42	48	11.0	3.6	G8		CP4448-318/9					
28.0	139.7	6	Bolted	6.4	156.43	123.0	5.58	D54	48	10.5	5.1	G4	Mtg flange stepped in 2.54mm	CP4448-81/2						
277.0	25.4	158.8	8	Bolted	6.4	174.1	141.0	4.82	D50	48	10.5	4.2	G4		CP4448-410/1					
278.0	16.0	176.1	8	Bolted	8.45	187.4	156.0	4.5	D44	24	6.5	2.5	G4/P		CP3770-1002/3					
	16.0	181.5	8	S/Bobbin	/	194.0	158.0	4.42	D38	24	6.5	2.4	CG4		CP3770-1014/5					
	16.0	193.5	8	S/Bobbin	/	210.9	170.0	4.425	D32	47	8.0	1.86	CG4	Bobbin CP2494-595MA	CP3947-112/3					
	18.0	193.5	8	S/Bobbin	/	210.9	170.0	4.42	D32	47	8.0	2.2	CG4		CP3947-102/3					
280.0	17.0	171.4	8	S/Bobbin	/	191.4	146.5	4.42	D43	24	6.5	2.9	CG8	Bobbin CP2494-595MA	CP3770-1018/9					
	17.0	176.8	8	Bolted	6.5	193.5	159.0	4.7	D43	24	6.5	2.5	G8		CP3770-1012/3					
	18.0	175.0	8	S/Bobbin	/	193.44	151.0	4.325	D42	47	8.0	2.8	CG4	Pro 5000+ Disc.	CP3947-138/9					
	18.0	190.5	8	Bolted	6.4	203.0	176.0	5.5	D38	28	8.8		G8		CP4541-102/3					
	20.0	176.8	8	S/Bobbin	/	192.0	154.0	5.0	D44	48	9.0		D/G4/G8	Bobbin CP2494-592MC	CP4348-862/3					
	21.0	175.0	8	S/Bobbin	/	193.44	151.0	5.625	D42	47	8.0	3.5	CG4	Pro 5000+ Disc.	CP3947-140/1					
	21.0	176.8	8	Bolted	6.4	192.0	159.3	4.8	D44	48	10.5		G4	Mtg flange stepped out 1.2mm	CP4448-746/7					
	22.0	175.0	8	S/bobbin	/	193.44	191.64	5.25	D42	48	10.5	3.3	CG4	Pro 5000+ Disc.	CP4448-208/9					
	22.2	165.1	8	Bolted	6.4	180.3	152.0	4.6	D51	48	10.5		G4		CP4448-752/3					
	22.9	158.8	8	Bolted	6.4	173.6	141.0	4.82	D51	00	10.5		G4		CP4448-158/9					
	23.0	176.8	8	Bolted	6.4	192.0	159.3	4.8	D44	48	10.5		G4		CP4448-744/5					
	25.4	158.8	8	Bolted	6.4	174.0	141.0	4.8	D51	48	10.5		G4	Mtg flange stepped in 1.2mm	CP4448-160/1					
	25.4	175.0	8	S/Bobbin	/	193.4	151.0	6.325	D42	48	10.5	4.1	CG4	Bobbin CP2494-504MP	CP4448-210/1					
	25.4	176.8	8	Bolted	6.4	192.0	159.3	4.9	D44	30	12.9	4.0	CG8	Pro 5000+ Disc	CP5000-312/3					
	25.4	176.8	8	S/Bobbin	/	192.0	154.0	5.0	D44	48	14.0	3.5	G4/G8	CP2494-592MC	CP3580-814/5					
25.4	177.8	12	Bolted	6.4	197.0	164.0	5.8	D41	48	10.5		G4		CP4448-856/7						
25.4	177.8	12	Bolted	6.4	197.0	164.0	4.9	D41	24	15.5	2.7	G8		CP3047-288/9						
285.0	25.4	158.8	8	Bolted	6.4	190.0	141.0	4.6	D51	48	10.5		G4	Mtg flange stepped in 1.27mm	CP4448-506/7					
	25.4	177.8	12	Bolted	6.4	197.0	164.0	4.9	D44	24	15.5	3.1	G8		CP3047-276/7					
	27.0	179.0	10	S/Bobbin	/	194.5	154.0	5.02	D44	54	16.0	3.7	GA	Bobbin CP2494-592MC	CP5254-104/5					
	28.0	158.8	8	Bolted	6.4	182.5	141.0	6.3	D51	48	10.5		G8		CP4448-268/9					
	28.0	177.8	12	Bolted	6.4	190.4	164.0	5.8	D46	36	15.25	4.0	CR8/G8		CP3837-1002/3					
32.0	175.0	10	S/Bobbin	/	190.5	150.0	5.02	D46	54	20.5	4.0	GA		CP5154-110/1						
290.0	20.7	177.8	12	Bolted	6.4	195.4	164.3	5.47	D46	48	9.0	3.6	G4		CP4348-896/7					
	25.4	165.1	8	Bolted	6.4	180.0	152.9	5.32	D54	48	9.0	5.2	CG8	Interchangeable	CP4348-2636/7					
					6.4	180.0	152.9	5.32	D54	48	14.0	4.5	G4		CP3580-2636/7					
28.0	165.1	8	Bolted	6.4	180.0	153.0	5.8	D54	30	15.2	5.1	G4		CP4448-680/1						
295.0	25.4	177.8	12	Bolted	6.4	193.0	164.0	5.9	D51	48	9.0		RD / G4		CP4348-894/5					
	25.4	177.8	12	Bolted	6.4	193.0	164.3	5.8	D51	48	14.0	4.3	G4/RD/P		CP3580-2894/5					
	25.4	177.8	12	Bolted	6.4	204.0	164.0	5.6	D44	48	9.3	5.4	CG8	Pro 5000+ Disc	CP5000-510/1					
	28.0	177.8	12	Bolted	6.4	193.0	164.0	5.9	D51	36	14.5		G4	Interchangeable	CP3837-102/3					
								5.6		24	15.5	4.1	G8		CP3047-256/7					
								6.6		48	14.0	5.0	G8/RD		CP3580-102/3					
28.0	177.8	12	S/Bobbin	/	192.4	154.0	5.6	D51	48	14.0	5.0	CG8	Bobbin CP2494-1341MD	CP3580-1134/5						
32.0	177.8	12	S/Bobbin	/	193.4	153.0	6.3	D51	48	14.0	5.8	CR8/RA	Bobbin CP2494-504MP	CP3580-394/5						

BRAKE DISCS - Ventilated Discs - Ø300mm to Ø355mm

Nominal Dimensions in (mm)													Max Pad Depth.	No. of Vanes.	Air Gap.	Weight Kg.	Face Types Available.	Comments.	Part Numbers.																																																																																																																																												
'A' Outside Dia.	'B' Thickness	Mounting Details			'C' (Eye) Ø.	'D' Inside Flange Ø.	'H' Mtg. Flange																																																																																																																																																								
	'M' P.C.D.	No.	Fixing Type. S/Bobbin = Standard CP2494. H/Bobbin = Heavy Duty CP4135 or CP7016	Ø.																																																																																																																																																											
300.0	24.0	189.0	8	Bolted	6.4	204.4	172.0	5.02	D47	48	9.0	4.5	G4		CP4348-106/7																																																																																																																																																
	25.4	190.0	8	Bolted	6.4	205.4	173.5	4.6	D46	24	15.5	3.3	G8		CP3047-398/9																																																																																																																																																
	25.4	196.2	12	Bolted	6.4	213.3	181.5	6.67	D42	48	9.0	4.6	P		CP4348-910/1																																																																																																																																																
	28.0	177.8	12	S/Bobbin	/	197.2	154.0	5.62	D50	48	14.0	5.0	RA		CP3580-1196/7																																																																																																																																																
	28.0	177.8	12	Bolted	6.4	203.2	164.0	5.6	D46	36	15.25	4.65	G8		CP3837-1004/5																																																																																																																																																
	28.0	181.0	8	S/Bobbin	/	195.0	160.0	5.42	D51	48	14.0	5.3	CG5	Brembo mounting	CP3580-1200/1																																																																																																																																																
304.0	20.7	177.8	12	Bolted	6.4	195.0	164.3	5.6	D55	48	9.0		G4		CP4348-626/7																																																																																																																																																
	24.0	190.5	12	Bolted	6.4	209.3	172.0	5.6	D46	48	9.0	4.65	CG8/CG12		CP4348-938/9																																																																																																																																																
	25.4	177.8	12	S/Bobbin	/	195.0	152.4	4.825	D53	24	15.5	3.65	G8	Bobbin CP2494-593MB	CP3047-320/1																																																																																																																																																
	25.4	177.8	12	Bolted	6.4	203.2	164.0	4.9	D50	24	15.5			G8		CP3047-230/1																																																																																																																																															
							164.3	6.6		48	9.0			G4		CP4348-528/9																																																																																																																																															
							164.5	4.9		48	14.0	4.4		G8		CP3580-230/1																																																																																																																																															
							164.0	4.9		36	14.5	4.1		G8		CP3837-230/1																																																																																																																																															
							164.0	4.9		48	14.0	4.3	GA/G4			CP3580-280/1																																																																																																																																															
	28.0	12	Bolted	6.4	205.8	177.6	177.6	4.92	D47	48	14.0	4.3	GA/G4			CP3580-66/7																																																																																																																																															
																	28.0	12	Bolted	6.4	201.4	161.0	6.6	D48	48	14.0	4.9	G8			CP3580-66/7																																																																																																																																
																																28.0	12	Bolted	6.4	203.2	164.0	5.6	D48	24	15.5	4.5	G8		CP3047-66/7																																																																																																																		
																																														28.0	12	Bolted	6.4	203.2	164.0	5.6	D48	48	14.0	5.2	G4		CP3580-2572/3																																																																																																				
																																28.0	12	Bolted	6.4	203.2	161.0	5.6	D50	54	16.0	4.6	GA/P																	CP5254-106/7																																																																																																			
																																														28.0	12	S/Bobbin	/	203.2	152.6	5.6	D50	24	15.5	4.6	G8				CP3047-66/7																																																																																																		
																																28.0	12	Bolted	6.4	203.2	170.0	6.57	D50	48	14.0	5.2	G8																	CP3580-1182/3																																																																																																			
	28.0	12	Bolted	6.4	210.6	174.0	5.6	D47	48	14.0		G8/RD			CP3580-1080/1																																																																																																																																																
																28.0	12	Bolted	6.4	209.3	174.0	5.6	D47	48	14.0	4.9	G4			CP3580-1126/7																																																																																																																																	
30.0	12	Bolted	6.4	191.0	158.0	5.6	D54	54	16.0	5.6	G4			CP5254-126/7																																																																																																																																																	
															32.0	12	Bolted	6.4	191.0	164.3	6.6	D51	48	14.0		G4			CP3580-2604/5																																																																																																																																		
28.0	12	Bolted	6.4	210.0	176.0	5.6	D50	24	15.5		G8			CP3047-212/3																																																																																																																																																	
															28.0	12	Bolted	6.4	211.3	174.0	6.6	D48	48	14.0	5.2	G8			CP3580-1058/9																																																																																																																																		
28.0	12	Bolted	6.4	220.0	190.0	5.6	D46	48	14.0	4.9	G8			CP3580-318/9																																																																																																																																																	
															32.0	8	Bolted	6.4	206.9	163.1	6.3	D51	48	16.5		G8			CP3784-6080/1																																																																																																																																		
315.0	22.0	200.0	12	Bolted	6.4	220.22	180.0	5.6	D46	48	9.0		G4																	CP4348-942/3																																																																																																																																	
															25.4	177.8	12	Bolted	6.4	195.0	164.5	5.3	D59	48	14.0	5.3	G4		CP3580-1012/3																																																																																																																																		
																															25.4	190.5	12	Bolted	6.4	210.3	172.13	5.5	D51	48	14.0	4.77	G8		CP3580-1096/7																																																																																																																		
																																														25.4	203.2	12	Bolted	6.4	220.0	190.0	5.8	D46	24	15.5	3.8	G8		CP3047-328/9																																																																																																			
																																																													28.0	177.8	12	Bolted	6.4	195.1	164.3	5.8	D60	48	14.0	5.9	D/G4		CP3580-2416/7																																																																																				
																																																																												28.0	177.8	12	Bolted	6.4	195.0	164.5	6.6	D60	48	14.0	6.2	G8		CP3580-64/5																																																																					
																																																																																											28.0	177.8	12	Bolted	6.4	210.3	164.3	5.9/6.1	D52	48	14.0	5.6	CG8	Pro 5000+ & < Disc	CP5000-220/1																																																						
																																																																																																										28.0	190.5	12	Bolted	6.4	210.3	174.0	6.57	D51	48	14.0	5.56	G8		CP3580-1034/5																																							
																																																																																																																									28.0	203.2	12	Bolted	6.4	220.0	190.0	5.6	D46	24	15.5	4.4	G8		CP3047-178/9																								
																																																																																																																																								32.0	177.8	12	Bolted	6.4	210.0	164.0	6.6	D51	24	15.5	6.0	G8		CP3580-178/9									
28.0	191.0	12	Bolted	6.4	217.3	177.6	5.92	D50	24	15.5	4.68	CG4																		CP3047-406/7																																																																																																																																	
															28.0	203.2	12	Bolted	6.4	217.3	190.0	5.57	D51	54	16.0	4.8	G8																																																																																																																																				
																															32.0	198.0	10	S/Bobbin	/	215.3	173.5	5.62	D51	61	20.0	5.3	CG8	Mtg flange stepped out 0.1mm																																																																																																																			
																																														32.0	203.2	12	Bolted	6.4	217.3	190.0	5.57	D51	48	16.0	6.1	G8																																																																																																					
																																																													325.0	28.0	203.2	12	Bolted	6.4	222.0	187.0	6.6	D51	48	14.0	5.8	G4/G8/RD																																																																																					
																																																																												328.0	28.0	203.2	12	Bolted	6.4	222.0	190.0	5.57	D52	24	15.5	5.0	G4																																																																						
																																																																																											32.0	217.0	8	S/Bobbin	/	233.1	192.0	6.3	D46	72	20.0	5.2	CG8	Bobbin CP2494-504MP																																																							
																																																																																																																									25.4	212.0	12	Bolted	6.4	228.0	196.0	5.3	D51	48	14.0	5.2	P																										
																																																																																																																																								25.4	220.5	12	Bolted	6.4	239.2	206.0	5.3	D45	48	14.0		G8											
																																																																																																																																																							26.0	200.0	12	Bolted	6.4	227.0	183.0	5.52	D50
26.0	203.2	12	Bolted	6.4	225.2	184.0	5.5	D51	48	14.0	5.1	CG8/GA																		CP3580-1180/1																																																																																																																																	
															28.0	196.85	12	Bolted	6.43	217.25	215.45	7.01	D55	48	13.5	6.1	CG8																																																																																																																																				
																															28.0	203.2	12	Bolted	6.4	220.0	190.0	5.6	D54	24	15.5	5.1	G8																																																																																																																				
																																														28.0	203.2	12	S/Bobbin	/	227.2	178.0	6.32	D50	48	14.0	5.8	CG8	Bobbin CP2494-504MP																																																																																																				
																																																													28.0	203.2	12	S/Bobbin	/	227.4	185.0	5.1	D51	36	14.5	4.94	CG8	Pro 5000+ & < Disc																																																																																					
																																																																												28.0	203.2	12	S/Bobbin	/	230.0	178.0	6.3	D50	48	14.0	5.6	G8																																																																							
																																																																																											28.0	203.2	12	Bolted	6.4	230.0	190.0	5.6	D50	48	16.5	5.2	G8																																																								
																																																																																																										28.0	203.2	12	Bolted	6.4	230.0	190.0	5.6	D50	48	14.0	5.94	CG8/G8/RD																																									
																																																																																																																									30.0	190.5	12	Bolted	6.4	217.2	172.0	5.575	D56	48	14.0	6.8	CR8																										
																																																																																																																																								32.0	203.2	12	Bolted	6.4	220.0	190.0	6.6	D54	48	19.5	5.8	G8											
																																																																																																																																																							32.0	203.2	12	S/Bobbin	/	227.0	178.0	5.6	D50
32.0	203.2	12																																																																																																																																																													

BRAKE DISCS - Ventilated Discs - Ø356mm to Ø410mm

Nominal Dimensions in (mm)														Max Pad Depth.	No. of Vanes.	Air Gap.	Weight Kg.	Face Types Available.	Comments.	Part Numbers.
'A' Outside Dia.	'B' Thickness	Mounting Details			'C' (Eye) Ø.	'D' Inside Flange Ø.	'H' Mtg. Flange	'M' P.C.D.	No.	Fixing Type. S/Bobbin = Standard CP2494. H/Bobbin = Heavy Duty CP4135 or CP7016	Ø.	'E' (Eye) Ø.								
356.0	28.0	228.6	12	Bolted	6.4	238.6	212.0	5.3	D54	48	16.5	5.8	CG12		CP3781-2126-7					
	28.0	228.6	12	Bolted	6.4	261.6	241.0	5.4	D46	48	16.5	5.5	G8		CP3781-2008/9					
	28.0	228.6	12	S/Bobbin	/	251.6	202.6	5.0	D51	48	16.5	5.4	CG8	Bobbin CP2494-592MC	CP3781-2024/5					
	28.0	240.0	12	Bolted	6.4	252.6	220.0	5.0	D51	48	16.5	5.3	CG8/GARA		CP3781-2142/3					
	32.0	228.6	12	S/Bobbin	/	254.5	203.0	5.6	D49	36	19.5	5.7	CG8 / RA	Bobbin CP2494-589MJ	CP3836-2048/9					
	32.0	228.6	12	S/Bobbin	/	244.6	202.8	5.6	D54	72	19.5	6.6	CG8/GA/G4		CP5772-1150/1					
										72 'S'	20.0	6.82	GA	'S' Vane Disc Bobbin CP2494-589MJ	CP6972-1150/1					
	32.0	228.6	12	Bolted	6.4	245.0	214.0	5.6	D54	48	19.5	6.7	CG24/GA/G8/P		CP3581-536/7					
						244.8	211.5	6.5	D51	72	17.0	7.4	G8		CP7177-110/1					
	32.0	228.6	12	Bolted	6.4	251.0	214.0	5.3	D51	48	19.5		CG8	Pro 5000+ & ⚡ Disc	CP5000-218/9					
	32.0	228.6	12	S/Bobbin	/	251.6	202.6	5.6	D51	48	19.5	6.6	G8/CG8	Bobbin CP2494-589MJ	CP3581-1080/1					
	32.0	240.0	12	Bolted	6.4	261.6	225.5	5.6	D46	48	19.5	5.7	G8 / P		CP3581-1038/9					
	32.0	240.0	12	S/Bobbin	/	258.0	215.0	5.6	D46	48	19.5		CG8	Interchangeable, Bobbin CP2494-589MJ	CP3581-1128/9					
						72				19.5	5.94	CG8 / GA		CP5772-1128/9						
	32.0	240.0	12	S/Bobbin	/	261.6	215.0	5.6	D46	48	19.5	5.8	G8	Interchangeable, Bobbin CP2494-589MJ	CP3581-1042/3					
										36		5.3	GA/CG8/D		CP3836-2000/1					
	36.0	228.6	12	Bolted	6.4	244.6	214.0	6.6	D54	48	19.5	7.7	CG8	Pro 5000+ Disc	CP5000-110/1					
	36.0	228.6	12	Bolted	6.4	245.0	208.0	6.4	D54	48	19.5	8.3	G8/GD/T2		CP3581-1096/7					
36.0	228.6	12	Bolted	6.4	245.0	214.0	6.6	D54	48	19.5	8.2	G8	Interchangeable	CP3581-516/7						
											9.4	G8		CP3781-516/7						
36.0	228.6	12	S/Bobbin	/	244.6	202.8	5.6	D54	48	19.5	7.6	G8	Interchangeable, Bobbin CP2494-589MJ	CP3581-1136/7						
									72	19.5	7.8	RA		CP5772-1136/7						
36.0	228.6	12	S/Bobbin	/	251.6	202.6	6.3	D51	72 'S'	20.0	8.0	RA	'S' Vane Disc	CP6972-1136/7						
									48	19.5	8.0	G8	Bobbin CP2494-504MP	CP3581-1078/9						
362.0	32.0	215.9	12	Bolted	6.43	238.0	195.0	6.42	D61	48	17.5	8.4	G8/CG12		CP4542-142/3					
	32.0	215.9	12	Bolted	6.4	251.0	195.0	6.43	D54	48	17.5	7.3	CG12		CP4542-112/3					
	32.0	228.6	12	Bolted	6.4	247.2	208.0	5.95	D55	72	19.5	6.99	GA		CP5772-168/9					
	32.0	228.6	12	Bolted	6.4	251.4	208.0	6.5	D54	48	17.5	7.8	G8/RD/T2		CP3718-1068/9					
366.0	32.0	240.0	12	Bolted	6.4	268.0	224.0	6.4	D48	48	17.5	6.5	G8/GA		CP3718-1088/9					
	40.0												RA		CP6072-104/5					
370.0	36.0	241.3	12	Bolted	6.4	252.0	224.0	6.6	D54	72	19.5	8.56	P/RA		CP5772-6072/3					
375.0	35.0	245.0	10	BREMBO MTG.			261.0	221.0	8.0	D54	72	19.5	8.52	P/RA	Mtg flange stepped out 1.0mm	CP5772-104/5				
	36.0	241.3	12	Bolted	6.4	257.0	225.0	6.6	D54	72	19.5	8.72	CG8/P/RA /RC		CP5772-6076/7					
	36.0	260.4	12	Bolted	6.4	269.7	245.0	6.6	D46	72	19.5	7.92	P/RA		CP5772-2072/3					
376.0	28.0	260.0	12	S/Bobbin	/	277.6	235.4	5.6	D47	48	17.5	5.1	G8	Bobbin CP2494-589MJ	CP3718-1000/1					
378.0	28.0	260.3	12	Bolted	6.4	282.0	244.0	6.07	D46	48	13.5	6.1	G12	Mtg flange stepped out 1.0mm.	CP5914-116/7					
	28.0	260.3	12	S/Bobbin	/	282.0	235.3	5.62	D46	48	13.5	6.28	G8		CP5914-110/1					
	32.0	235.8	10	Bolted	8.4	250.0	218.0	7.0	D64	48	16.0		CR8	Interchangeable	CP3784-2098/9					
	32.0	235.8	10	Bolted	8.4	250.0	220.0	7.0	D64	48	17.5		G8		CP3718-2020/1					
	32.0	240.0	12	S/Bobbin	/	267.0	214.5	5.6	D54	36	19.5	6.6	CG8/GA	Interchangeable, Bobbin CP2494-589MJ	CP3836-1030/1					
						48	17.5	7.2	CG8/G8	CP5772-1030/1 is a Pro 5000 ⚡ Disc	CP3718-1030/1									
						72	19.5	7.16	CG8/GA/P		CP5772-1030/1									
						72 'S'	20.0	7.46	CG8/GA	'S' Vane Disc Bobbin CP2494-589MJ	CP6972-1030/1									
	32.0	260.4	12	Bolted	6.4	282.6	243.8	5.8	D48	36	19.5	5.8	GA		CP3836-2002/3					
	32.0	260.4	12	S/Bobbin	/	282.7	235.0	5.625	D46	36	19.5	5.87	CG8/GA	Bobbin CP2494-589MJ	CP3836-1010/1					
	32.0	260.4	12	S/Bobbin	/	282.0	235.5	5.6	D46	72	19.5	6.2	D/GA		CP5772-1010/1					
							235.35	5.6	D46	72 'S'	20.0	6.4	GA	'S' Vane Disc Bobbin CP2494-589MJ	CP6972-1010/1					
	34.0	248.0	12	H/Bobbin	/	266.85	223.0	6.32	D54	84	21.5	7.9	GA	Bobbin CP4135-106FP	CP4284-2098/9					
	36.0	240.0	12	S/Bobbin	/	264.9	216.0	5.6	D54	48	17.5	8.9	CG8/GA		CP3718-2068/9					
36.0	240.0	12	S/Bobbin	1	264.0	214.5	5.6	D54	72	19.5	8.9	CG8/CR24 /RA	Bobbin CP2494-589MJ CP5772-1032/3 is a Pro 5000 ⚡ Disc	CP5772-2068/9						
														CP5772-1032/3						
36.0	240.0	12	S/Bobbin	/	266.0	215.0	5.6	D54	72	19.5		G8		CP5772-1032/3						
													72 'S'	20.0	8.9	RA	'S' Vane Disc Bobbin CP2494-589MJ	CP6972-2068/9		
36.0	247.6	12	H/Bobbin	/	266.8	221.0	7.5	D54	72	20.0	8.7	CG8/GA	Wide Bobbin Disc CP7016-139MS	CP5772-2084/5						
380.0	32.0	228.6	10	S/Bobbin	/	247.0	202.2	5.6	D66	72	19.5	8.4	CG8	Bobbin CP2494-589MJ	CP5772-118/9					
	40.0	240.0	12	S/Bobbin	/	266.0	216.0	5.4	D54	72	25.5	8.8	CR24/RA		CP6072-102/3					
390.0	34.0	260.0	12	Bolted	6.4	268.8	243.0	6.14	D54	84	21.0	8.4	CG24		CP4284-102/3					
	34.0	260.0	12	Bolted	6.4	278.8	243.0	6.14	D54	84	21.0	8.0	CG24		CP4284-112/3					
	36.0	260.0	12	Bolted	6.4	268.8	243.0	6.3	D54	54	19.0	9.3	CG24		CP4095-100/1					
	36.0	260.0	12	Floating	/	278.75	235.0	6.8	D54	84	21.0	8.7	CG8	Pro 5000 ⚡ Disc	CP4284-134/5					
400.0	36.0	270.0	12	Bolted	6.4	288.7	253.2	7.0	D54	73	19.0	9.3	CG12		CP4095-104/5					
410.0	36.0	245.5	12	Bolted	8.25	266.0	225.5	8.10	D70	73	19.0		CG8/G8	Heavy Duty	CP4095-102/3					

BRAKE DISCS - Ventilated Disc / Bell Kits and Ventilated with Integral Bell

VENTILATED DISC AND OR BELL KITS.

AP Racing now produce disc and bell kits as aftermarket alternatives for OE discs.

These kits are designed to replace the standard single piece disc and retaining the vehicles production brake caliper.

The kits include either strap drive, bolted or floating discs and/or bell assemblies (see tables below & opposite) and for the kits with pads a set of Ferodo DS2500 material.



Note:-

On the Strap Drive kits for Subaru and Mitsubishi Evo installations the AP Racing kit requires a shallower pad than the original pad to enable them to clear the strap drive system.

Strap Drive Replacement OE Disc Kits

Application	Disc & Bell Kits.	Disc, Bell & Pad Kits.
Audi		
S3 (8P) 2006-2012	CP6890-001MNP.G8	
Mitsubishi		
Evo 7 / 8 / 9. Fitted with Brembo 4 pots. Grooved disc	CP6890-009MNP.T2	CP6890-009M.T2
Subaru		
Impreza 01 on & Including N14 models. Fitted with Brembo 4 Pot.	CP6890-007MNP.CG8	CP6890-007M.CG8
VW		
Golf MKV R32. 2005 on.	CP6890-001MNP.G8	

Floating in the Bell Replacement OE Disc Kits

Important Note: CP8080 Kits do not include mounting bells. These need to be purchased separately. Bobbin Kits are included.

Audi	
RS4 - B7 Front. - Ø365 x 34mm disc fits OEM Brembo 8 Piston Caliper.	- RH = CP8080Z14SD / LH = Z15SD - Mounting Bell = CP8080Z140.
RS6 - C5 Front. - Ø365 x 34mm disc fits OEM Brembo 8 Piston Caliper.	- RH = CP8080Z14SD / Z15SD - Mounting Bell = CP8080Z141.
RS6 - C6 Front. - Ø390 x 36mm disc fits OEM Brembo 8 Piston Caliper (2008 - 2010)	- RH = CP8080Z24CG12 / LH = Z25CG12 - Mounting Bell = CP8080Z240.
RS6 - C6 Rear. - Ø356 x 26mm disc fits OEM Caliper.	- RH = CP8080Z26CG12 / LH = Z27CG12 - Mounting Bell = CP8080Z260.
R8 - Front. 2007 - on - Ø365 x 34mm disc fits OEM Brembo 8 Piston Caliper.	- RH = CP8080Z48SD / LH = Z49SD - Mounting Bell = CP8080Z480.
R8 - Rear. - Ø355 x 32mm - Directly replaces standard Ø355 x 32mm, 2 Piece disc with OEM calipers.	- RH = CP8080Z50SD / LH = Z51SD - Mounting Bell = CP8080Z500.
Installation Note - OEM Caliper Noise bar must be removed for disc mounting bolt clearance.	
Ford Focus RS Mk2 (2009 on). - Ø336 x 28mm disc.	- RH = CP8080Y18CG8 / LH = Y19CG8 - Mounting Bell = CP8080Y180

Nissan

GT-R, R35 - Front 2011 on - Ø390x34mm disc. - Face types available include CG12, GA & SD.	- RH = CP8080Y10CG12 / LH = Y11CG12 - Mounting Bell = CP8080Y100
GT-R, R35 - Front 08-2011. - Ø378x34mm Disc. - Face types available include CG12, GA & SD	- Grooved Part No = CP4590-033YNP.CG12.
GT-R, R35 - Rear 2008 on - Ø378x30mm disc. - Face types available include CG12, GA & SD	- Grooved Part No = CP4590-034YNP.CG12.

Mitsubishi

Evo X. Fitted with Brembo 4 pots - Other face types available include - CG12	- Plain Part No = CP4590-032YNP.P
---	-----------------------------------

Bolted Disc and Bell OE Replacement Kits

Ford Focus RS MK1	CP4590-007BNP.CG8
Renault Megane 225.	CP4590-011BNP.CG8

VENTILATED BRAKE DISCS WITH INTEGRAL MOUNTING BELL.

This section on ventilated brake discs with integral mounting bell provides dimensional details, as well as information on face types and the weight of the most popular discs from within the ventilated integral disc range. **Not all discs are listed**, should you require a disc with particular dimensions which is not listed please contact the AP Racing Technical Section for assistance.

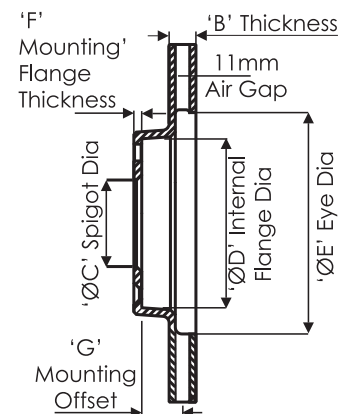
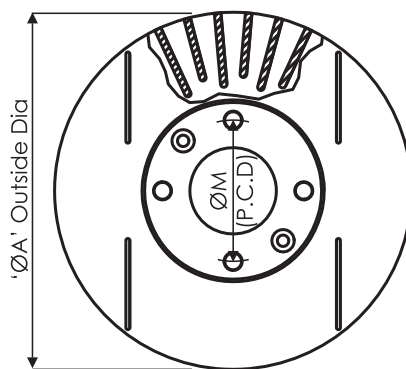
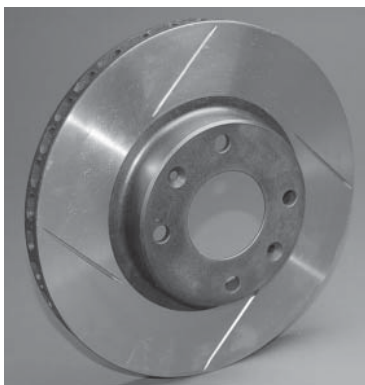

Nominal Dimensions in (mm)											Max Pad Depth.	Weight Kg.	Face Types.	Part Number.
'A' Outside Dia.	'B' Thickness	Mounting Details			'C' Spigot Dia.	'D' Internal Flange Dia.	'E' Eye Dia.	'F' Mtg Flange Thickness.	'G' Mtg Offset.					
		'M' P.C.D.	No.	Dia.										
254.0	20.7	100.0	4	14.7	62.0	121.3	170.0	8.2	38.2	D41	4.3	G4	CP2589-120	
262.0	20.1	108.0	4	12.9	66.1	131.0	156.0	6.0	31.0	D50	4.2	G4	CP2589-115	
270.0	22.0	108.0	4	12.4	65.26	129.1	165.0	6.0	30.7	D52	4.8	G4 / G8	CP2589-138	
273.0	20.5	108.0	4	12.9	66.1	129.0	169.0	6.0	30.2	D50	4.5	G4	CP2589-135	
304.0	24.0	100.0	4	12.2	64.2	180.0	200.0	7.5	26.0	D46		SD / P / G8	CP7080-104	
328.0	20.0	120.0	5	14.6	75.0	185.08	234.0	7.17	44.05	D48		G8	CP4475-122/3	

BRAKE DISCS - Solid and Solid with Integral Bell

SOLID BRAKE DISCS.

This section on solid brake discs provides dimensional details, as well as information on face types and the weight of the most popular discs from within the solid disc range.

Note:

Not all solid discs are listed, should you require a disc with particular dimensions which is not listed please contact AP Racing Technical Section for assistance.

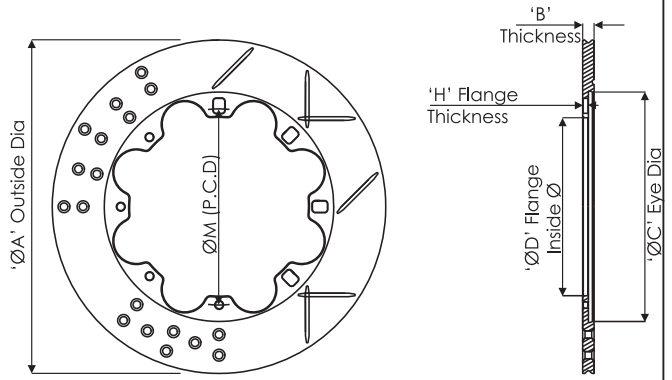

Nominal Dimensions in (mm)											Max Pad Depth.	Weight Kg.	Face Types Available.	Comments.	Part Numbers.
'A' Outside Dia.	'B' Thickness	Mounting Details				'C' Eye Ø.	'D' Inside Flange Ø.	'H' Mtg. Flange.							
		'M' P.C.D.	No.	Fixing Type.	Ø.										
254.0	8.0	146.0	8	Bolted	8.45	165.0	131.0	6.0	D44		G4	Mtg Flange Stepped out 2.0mm	CP2866-215		
	8.0	146.0	8	Bolted	8.45	165.0	131.0	6.0	D44		G4	Mtg Flange Stepped out 0.75mm	CP2866-218		
	9.7	151.0	8	Bolted	6.4	166.0	134.0	4.8	D44		G4		CP2866-204		
260.0	9.5	139.7	6	Bolted	7.95	172.7	123.2	5.1	D44		G4		CP2866-229		
265.0	7.1	158.8	8	Bolted	6.4	177.0	141.0	4.8	D44		D / G4		CP2866-195		
	8.0	158.8	8	Bolted	6.4	189.0	141.0	4.8	D38		G8		CP2866-214		
	9.6	158.8	8	Bolted	6.4	177.0	141.0	4.8	D44	2.0	D / G4 / G8 / P		CP2866-179		
	9.6	158.8	8	Floating	/	177.0	135.7	4.8	D44	2.1	D / G4 / G8 / P	Bobbin CP2494-593MB	CP2866-193		
277.0	9.6	176.8	8	Bolted	6.4	192.0	159.0	4.8	D43	2.4	G4 / G8		CP2866-178		
	9.6	176.8	8	Floating	/	192.0	154.0	4.8	D43	2.3	D / G4 / G8	Bobbin CP2494-593MB	CP2866-192		
	9.6	181.5	8	Floating	/	197.6	159.3	4.8	D40	2.2	G4	Bobbin CP2494-593MB	CP2866-203		
280.0	7.0	172.5	5	Floating	/	192.0	190.2	4.47	D44	1.76	G4	Bobbin CP2494-595MA	CP2866-239		
	7.0	169.3	6	Floating	/	192.0	190.2	4.47	D44	1.8	G4	Bobbin CP2494-595MA	CP2866-238		
	9.6	169.8	8	Floating	/	192.0	149.3	4.8	D44	2.4	G4	Bobbin CP2494-593MB	CP2866-194		
	9.6	175.0	8	Bolted	6.4	191.5	158.0	4.8	D44		D / G8		CP2866-223		
	9.6	176.8	8	Bolted	6.4	192.0	159.0	4.8	D44	2.5	D / G4 / G8		CP2866-177		
	9.6	176.8	8	Bolted	6.4	192.0	159.0	4.8	D44	2.5	CG4	Pro 5000+ Disc	CP5000-177		
10.0	172.5	5	Floating	/	192.0	190.2	4.47	D43	2.47	G4	Bobbin CP2494-595MA	CP2866-240			
290.0	10.0	180.0	8	Floating	/	201.7	155.0	5.8	D44	2.6	G8	Bobbin CP2494-589MJ	CP2866-237		
295.0	10.0	176.8	8	Bolted	6.4	192.0	159.0	4.8	D48		G8		CP2866-200		
300.0	9.6	189.0	8	Bolted	6.4	206.5	171.0	4.6	D46	2.5	D / P		CP2866-196		

SOLID BRAKE DISCS WITH INTEGRAL MOUNTING BELL.

This section on solid brake discs with integral mounting bell provides dimensional details, as well as information on face types and the weight of the most popular discs from within the solid integral disc range. **Not all discs are listed,** should you require a disc with particular dimensions which is not listed please contact the AP Racing Technical Section for assistance.

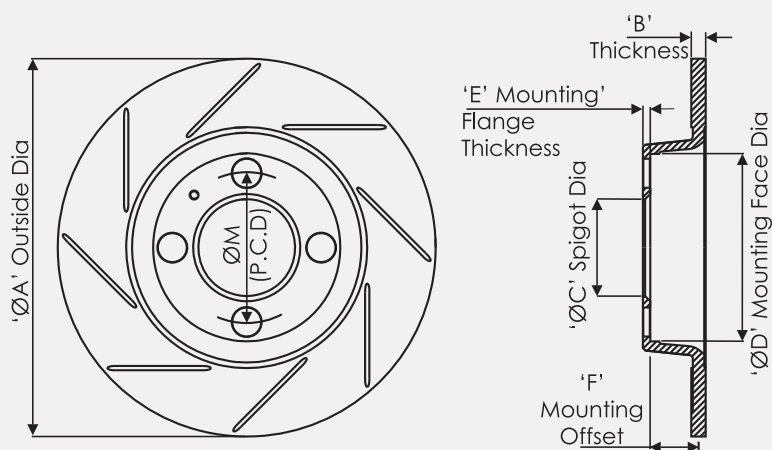

Nominal Dimensions in (mm)											Max Pad Depth.	Weight Kg.	Face Types.	Part Number.
'A' Outside Dia.	'B' Thickness	Mounting Details			'C' Spigot Dia.	'D' Mtg Face Dia.	'E' Mtg Flange Thickness.	'F' Mtg Offset.						
		'M' P.C.D.	No.	Dia.										
248.0	7.1	95.25	4	9.5	76.2	128.0	5.1	32.5	D46	2.4	P	CP2222-9		
254.0	9.7	95.25	4	9.5	76.2	128.0	5.1	31.5	D46	3.3	P	CP2222-10		
	9.7	100.0	4	12.5	72.6	127.7	5.1	31.5	D43	2.8	G4	CP2222-273		
264.0	11.1	107.95	4	11.6	86.36	133.35	7.87	16.8	D52	3.8	P	CP2407-129		

BRAKE DISCS - Castings and Face Types

DISC CASTING TYPES.

Details of the various disc castings types available from AP Racing are given below to help you choose the correct disc for your application.

NB. AP Racing do not supply unmachined castings, as all disc go through special heat treatments processes during manufacture.

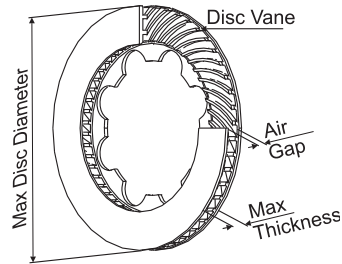

CP2222 Solid with Int/Bell Max Dia = Ø280mm Max Thickness = 22mm	CP2407 Solid with Int/Bell Max Dia = Ø278mm Max Thickness = 12mm	CP2866 Solid Max Dia = Ø304mm Max Thickness = 10mm
CP2589 Ventilated with Int/Bell. No. of Vanes = 30 Air Gap = 15.25mm Max Dia = Ø280mm Max Thickness = 21mm	CP3047 Ventilated Curved Vane. No. of Vanes = 24 Air Gap = 15.5mm Max Dia = Ø343mm Max Thickness = 32mm	CP3575 Ventilated with Int/Bell. No. of Vanes = 36 Air Gap = 16mm Max Dia = Ø330mm Max Thickness = 36mm
CP3580 Ventilated Curved Vane. No. of Vanes = 48 Air Gap = 14mm Max Dia = Ø332mm Max Thickness = 28mm	CP3581 Ventilated Curved Vane. No. of Vanes = 48 Air Gap = 19.5mm Max Dia = Ø356mm Max Thickness = 36mm	CP3718 Ventilated Curved Vane. No. of Vanes = 48 Air Gap = 17.5mm Max Dia = Ø378mm Max Thickness = 36mm
CP3770 Ventilated Curved Vane. No. of Vanes = 24 Air Gap = 6.5mm Max Dia = Ø285mm Max Thickness = 18mm	CP3781 Ventilated Curved Vane. No. of Vanes = 48 Air Gap = 16.5mm Max Dia = Ø356mm Max Thickness = 36mm	CP3784 Ventilated Curved Vane. No. of Vanes = 48 Air Gap = 16mm Max Dia = Ø380mm Max Thickness = 36mm
CP3836 Ventilated Curved Vane. No. of Vanes = 36 Air Gap = 19.5mm Max Dia = Ø380mm Max Thickness = 36mm	CP3837 Ventilated Curved Vane. No. of Vanes = 36 Air Gap = 14.5mm Max Dia = Ø332mm Max Thickness = 36mm	CP3847 Ventilated Curved Vane. No. of Vanes = 36 Air Gap = 20mm Max Dia = Ø328mm Max Thickness = 32mm
CP3860 Ventilated Curved Vane. No. of Vanes = 60 Air Gap = 18mm Max Dia = Ø310mm Max Thickness = 36mm	CP3870 Ventilated Curved Vane. No. of Vanes = 70 Air Gap = 16.5mm Max Dia = Ø330mm Max Thickness = 36mm	CP3930 Ventilated Curved Vane. No. of Vanes = 30 Air Gap = 15.5mm Max Dia = Ø343mm Max Thickness = 36mm
CP3947 Ventilated Curved Vane. No. of Vanes = 47 Air Gap = 8mm Max Dia = Ø295mm Max Thickness = 22mm	CP3948 Ventilated Curved Vane. No. of Vanes = 48 Air Gap = 21mm Max Dia = Ø332mm Max Thickness = 36mm	CP4095 Ventilated Curved Vane. No. of Vanes = 73 Air Gap = 19mm Max Dia = Ø410mm Max Thickness = 36mm
CP4136 Ventilated Straight Vane. No. of Vanes = 36 Air Gap = 9.3mm Max Dia = Ø285mm Max Thickness = 28mm	CP4661 Ventilated Curved Vane. No. of Vanes = 61 Air Gap = 20mm Max Dia = Ø332mm Max Thickness = 42mm	CP4248 Ventilated Curved Vane. No. of Vanes = 48 Air Gap = 16mm Max Dia = Ø332mm Max Thickness = 30mm
CP4284 Ventilated Curved Vane. No. of Vanes = 84 Air Gap = 21mm Max Dia = Ø410mm Max Thickness = 36mm	CP4348 Ventilated Curved Vane. No. of Vanes = 48 Air Gap = 9mm Max Dia = Ø315mm Max Thickness = 28mm	CP4378 Ventilated with Int/Bell. No. of Vanes = 44 Air Gap = 18mm Max Dia = Ø378mm Max Thickness = 40mm
CP4448 Ventilated Curved Vane. No. of Vanes = 48 Air Gap = 11mm Max Dia = Ø295mm Max Thickness = 36mm	CP4470 Ventilated Curved Vane. No. of Vanes = 70 Air Gap = 24.5mm Max Dia = Ø332mm Max Thickness = 42mm	CP4540 Ventilated Curved Vane. No. of Vanes = 28 Air Gap = 8.82mm Max Dia = Ø300mm Max Thickness = 22mm
CP4542 Ventilated Curved Vane. No. of Vanes = 48 Air Gap = 17.5mm Max Dia = Ø366mm Max Thickness = 32mm	CP4670 Ventilated Curved Vane. No. of Vanes = 70 Air Gap = 22mm Max Dia = Ø332mm Max Thickness = 38mm	CP5125 Ventilated with Int/Bell. No. of Vanes = 36 Air Gap = 8mm Max Dia = Ø282mm Max Thickness = 23mm
CP5154 Ventilated Curved Vane. No. of Vanes = 54 Air Gap = 20.5mm Max Dia = Ø334mm Max Thickness = 36mm	CP5254 Ventilated Curved Vane. No. of Vanes = 54 Air Gap = 16mm Max Dia = Ø334mm Max Thickness = 32mm	CP5772 Ventilated Curved Vane. No. of Vanes = 72 Air Gap = 19.5mm Max Dia = Ø380mm Max Thickness = 40mm
CP5775 Ventilated Curved Vane. No. of Vanes = 72 Air Gap = 17.5mm Max Dia = Ø378mm Max Thickness = 33mm	CP5914 Ventilated Curved Vane. No. of Vanes = 48 Air Gap = 13.5mm Max Dia = Ø380mm Max Thickness = 32mm	CP6072 Ventilated Curved Vane. No. of Vanes = 72 Air Gap = 25.5mm Max Dia = Ø380mm Max Thickness = 42mm
CP6972 Ventilated 'S' Vane. No. of Vanes = 72 Air Gap = 19.5mm Max Dia = Ø380mm Max Thickness = 40mm	RP6565 Ventilated Curved Vane. No. of Vanes = 48 Air Gap = 13.5mm Max Dia = Ø366mm Max Thickness = 32mm	RP7177 Ventilated Curved Vane. No. of Vanes = 72 Air Gap = 17mm Max Dia = Ø390mm Max Thickness = 36mm

DISC FACE TYPES.

Disc Grooves and sometimes cross drilling are normally used on all racing brake discs to clean the surface of the pad & allow gases produced to escape. In doing so the friction characteristics are modified.

Different groove and drilling patterns affect the friction characteristic in different ways, some affect overall friction and others the bite or release characteristics & therefore the best solution is not necessarily the same for each application.

AP Racing is constantly developing and refining disc face patterns and new variations will be introduced from time to time. The most popular face types are detailed below and the page opposite.

N.B. Not all Face Types are available for every disc.



P = Plain.
(No grooves or holes). Mainly used for road cars where low noise is vital.



G4,G8,G12 & G24 = Grooved.
(Straight forward facing). The number specifies grooves per face. Traditional style groove



CG4,CG8,CG12 & CG24 = Curved Grooves. (Backward facing). The number specifies grooves per face. **Standard pattern.**



CR4, CR8, CR12 & CR24 = Curved Grooves. (Backward facing running out on O/D to clear debris. Only used on thick wall discs). The number specifies grooves per face.



RD = Radiused Drilled.
(Cross drilled but with radiused run out to reduce noise & improve life compared with standard cross drilling. Usually used on Road applications.



D & SD = Cross Drilled.
(Drilled holes chamfered). Still preferred with some pad materials but can compromise disc life.

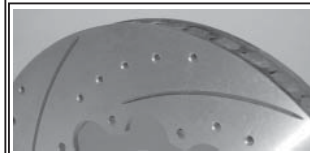

GD = Grooved & Drilled.
Usually used on Road applications.



PG = Partial Groove.
Shorter length groove pattern



RA = 'J' Hook Design.
Gives improved bite and debris clearance and reduces distortion / vibration, outer grooves run out to O/D. Thick wall discs only

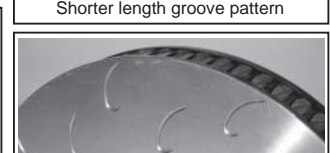

GA = 'J' Hook Design.
Latest design gives improved bite & debris clearance & reduces distortion / vibration, outer grooves do not run out to O/D.



RC = 'J' Hook Design.
As RA design but with 3 hooks across face. This design gives improved bite and debris clearance and reduces distortion / vibration. Thick wall discs only



T2= Continuous Grooves.
Two continuous grooves per face. Usually for road and Brake Kit applications.

DISC MOUNTING.

Most racing and many high performance road brake discs are designed to be mounted on to the hub or stub axle by means of a mounting bell. Mounting bells are usually made from high grade Aluminium alloy although other materials can be used.

This arrangement is much lighter than a one piece disc and bell, but more importantly allows some compliance to reduce the risk of distortion due to heat expansion of the disc. This becomes more important the larger the disc and is considered essential above Ø330mm diameter. There are essentially two methods of attaching the disc to the bell, 'Bolted' and 'Floating'. The method to be used will depend on the particular application.

BOLTED.

For lower duty applications and on smaller discs a bolted mounting is sometimes preferred for strength and simplicity especially for off-road application (e.g. Rallies) where debris may clog a floating mechanism leading to run-out and disc vibration. Stiff flat bells should be avoided with a bolted mounting.

Standard AP Racing disc mounting hole size is 6.40 / 6.45mm diameter. AP Racing offer a range of bolts, nuts and washers to suit. These are also available in wheel set kits, see below for details.

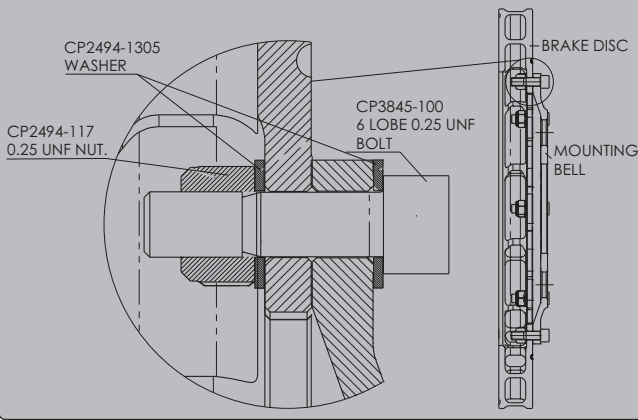

BOLTS AND BOLT KITS.

E8 - 6 Lobe Headed Bolt kits available for AP Racing discs are given in the table below. The 6 Lobe bolt offers the following advantages over a cap head:

- More positive drive.
- More consistent clamping loads.
- Lighter.
- Better corrosion resistance
- Less prone to damage.
- Improved airflow.



BOLT DIMENSIONS.

AP Racing recommend a bolt / nut tightening torque for a disc and bell of 14Nm (10.5Lb/ft).

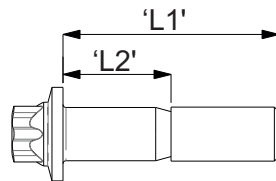

Bolt Dimensions and Part Numbers. (Dim'n in mm)					
Bolt Part No.	Dim'n 'L1'	Dim'n 'L2'	Bolt Part No.	Dim'n 'L1'	Dim'n 'L2'
CP3845-100	22.2	9.5	CP3845-107	30.2	17.5
CP3845-101	25.4	12.7			
CP3845-102	27.0	14.3			

E8, 6-LOBE HEAD BOLT KITS (All Bolts 1/4" UNF).

Kit Part No.	No. of Bolts in kit.	Bolt Part No.
CP3845-100K08	8	CP3845-100 - .875" long.
CP3845-102K10	10	CP3845-102 - 1.062" long.
CP3845-100K12	12	CP3845-100 - .875" long.
CP3845-101K12	12	CP3845-101 - 1.0" long.
CP3845-102K12	12	CP3845-102 - 1.062" long.

Each of the above kits contain the required number of CP2494-117 Nut & CP2494-1305 washer.

Note: 3/8" E8, 6-Lobe Socket - CP2494-153 is available

NOTE: Bolts, nuts and washers are not available separately, but can be purchased in boxes of 100.

The Cap Head bolt will continue to be available as a loose part in kits of 100.

Individual Bolt, Nuts and Washer Components in boxes of 100.		
Component.	E8 - 6-Lobe Head Type Part Nos.	Alternative Cap Head Type Part Nos.
.875" Long Bolt.	CP3845-100K100	CP2494-116K100
1.00" Long Bolt.	CP3845-101K100	CP2494-718K100
1.062" Long Bolt.	CP3845-102K100	CP2494-331K100
Nut.	CP2494-117K100	
Washer.	CP2494-1305K100	
N.B. BOLTS, NUTS AND WASHERS NOT SOLD INDIVIDUALLY		

FLOATING.

Discs for heavy duty applications, especially larger discs, should be mounted to allow some axial & radial float between disc & bell. This may be achieved by the following methods:-

- 'Float in the bell',
- 'Float in the disc',
- or 'Strap Drive'.

Radial float allows differential expansion of disc and bell thus reducing stresses in the disc and minimising disc cracking and distortion. The idea of axial float is to compensate for a certain amount of stub axle / upright flex by allowing the disc to take up its ideal position within the range of float thus avoiding 'Knockback' of the caliper pistons. However the float should not be excessive as disc gyroscopic loads can cause the same effect that the float is meant to alleviate.

The amount of axial float will depend somewhat on the application. In a 'perfect' system with minimal disc movement relative to the Caliper the amount of float need only be around 0.15 - 0.25mm.

'FLOAT IN THE BELL'.

The AP Racing 'Float in the Bell' system has the advantage of being used with standard bolted discs, float is controlled by bell thickness. During use some wear of the bell inevitably occurs which tends to increase float and requires more frequent Bell replacement than the Float in the Disc system.

NOTE.

Recommended bell flange thickness for use with this bobbin is 8.00 / 8.05 to give 0.15 / 0.25mm float.

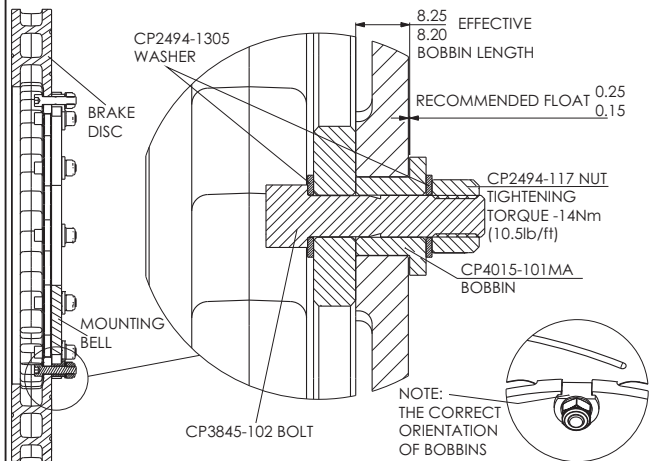

CP4015 Float in the bell Bobbins.

The bobbin for use with 'float in the bell' mounting is CP4015-101MA

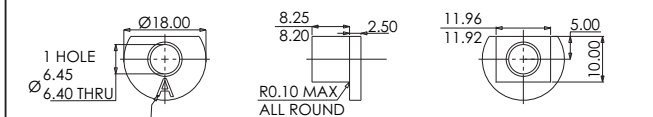

Bobbin kit CP4015-101K12

CP4015-101MA bobbin can be bought separately or in a kit which contains the bobbins, bolts, nuts & washers.

DISC OPERATING ADVICE.

This section on operating advice has been produced as a guide only, as many formula or racing series may have different requirements.

DISC TEMPERATURES.

In order to achieve optimum racing brake performance and prolong disc life it is essential that the brakes operate at the correct temperature. In general discs should run at similar temperatures front and rear and from side to side, dissimilar temperatures will lead to varying brake balance. Temperature balance can be checked as soon as the car stops in the pit lane using a Pyrometer such as AP Racing Pyrometer kit CP2640-24 (see below). However a pyrometer reading is not a good indicator of disc operating temperature which decays rapidly with time when the brakes are not being applied. Under racing conditions disc bulk temperatures should normally be maintained in the range 400°C to 600°C for best performance. Disc face peak temperatures may be higher but should not exceed the maximum recommended for the pad material being used. An effective method of checking maximum disc operating temperature is by using temperature paints applied to the disc. A suitable paint kit can be obtained under AP Racing Part No. CP2649-1, this kit contains three paints, Green (430°C), Orange (560°C) and Red (610°C) plus thinners and brushes. When assessing brake temperatures it is important to complete several successive laps (5 or preferably 10) at race speeds and vehicle weight to allow temperatures to stabilise at a representative level. Typically when running within the correct temperature range the Green paint (430°C) will turn throughout, the Orange paint (560°C) 50% to 100% throughout and the Red paint (610°C) turned up to 5mm from each brake face. If the Red paint (610°C) turns throughout, the discs are running too hot. Circumferential disc face ridges are also an indication of running too hot. Circuits and drivers vary enormously in the amount of work they demand from the brakes and therefore the brake system has to be tuned for each circuit by adjustment of the cooling airflow. The temptation to over cool the disc should be resisted.

The aim is to keep the temperature as stable as possible within the working temperature range. High maximum to low minimum temperature cycles are the enemy of disc life and cause performance variations.

TEMPERATURE MEASUREMENT.**DIGITAL READ-OUT PYROMETER**

CP2640-24 Digital pyrometer for brake, disc and tyre temperatures. High accuracy display reads in centigrade. The unit comes complete with probes for both brake discs and tyres in a heavy duty carry case.

**THERMAL PAINT KITS**

CP2649-1 kit comprises of three paints for monitoring peak Brake Disc temperatures. The three paints are:-

- Green changes colour to White at 430°C.
- Orange changes colour to Buff at 560°C.
- Red changes colour to White at 610°C.

The kit also comprises, one bottle of thinners and three brushes.

BRAKE CALIPER TEMPERATURE STRIPS

CP2650-11 Temperature indicator strips for monitoring caliper temperatures.

- Temperature range 149°C to 260°C
- Each packet contains 10 strips.

**TEMPERATURE RECORDING PAD**

CP2640-25 Allows the user to record temperature data for Brake Discs and Brake Calipers.

**DISC COOLING.**

A good source of cooling air should be supplied preferably through the up-right to the disc throat. A typical venting cross section of 100cm² (16in²) is usually sufficient. The pick up should preferably be in an area of clean high pressure air flow and the ducting should be arranged to avoid sharp bends or changes in section which may choke the air flow. Careful design of the Mounting Bell is important in achieving effective disc cooling and avoiding problems. Typically 80% of the airflow should be directed up the disc vents and 10% up each face of the disc. This ratio can vary considerably in practice but it is important that both disc faces are cooled equally by adjusting the air gaps. Unequal face temperatures can lead to disc distortion and a long pedal. Lightening holes in the bells should be avoided as available cooling air can be lost without cooling the disc.

DISC BEDDING.

All cast iron brake discs need to be bedded-in to ensure heat stabilisation and improve resistance to cracking. Cracks or even disc failure can occur during the first few heavy stops if careful bedding is not carried out.

AP Racing recommend the following procedures or visit www.apracing.com for the latest advice.

RACE CAR INSTALLATIONS:

1) If ducts are fitted they should be ¾ blanked off. 2) Use previously bedded pads. 3) For a minimum of 15Km use brakes gently at first from initially low speeds - Progressively raise speed to normal racing speed but still using gentle applications. 4) For the final 2 or 3 applications brakes can be used quite heavily. 5) If AP Racing thermal paints are used then only the Green paint (430°C) should have fully turned to white and maybe also just the Orange paint (560°C) on the outside edges of the discs during the bedding procedure. 6) Allow to cool. 7) AP Racing offer a pre-bedding service at nominal extra charge. This ensures that discs are bedded consistently assuring better performance & life. Contact AP Racing for details.

ROAD CAR INSTALLATIONS:

1) For the first 10 miles, light braking from 50/60 mph down to 30 mph if possible in blocks of 5. Do not attempt any high-speed stops down to zero at this point, as only the faces will heat up with the mass remaining cool along with the mounting area. 2) For the next 100 miles increase the braking pressures similar to stopping in traffic, again avoiding if possible full stops from above 70 mph. By now the area around the mounting bolts should be a light blue temper colour. This is a good indication that the correct heat soak has been achieved. 3) For the next 100 miles gradually increase the braking effort after this full power stops can be used. The disc should now be an even dark to light blue temper colour, depending on the pad type and the braking effort being used during the process.

This process must be completed before any race circuit use.

Track Day Use: For the latest Track Day Bedding Instructions visit our website: <http://www.apracing.com/Info.aspx?InfoID=73&ProductID=30>

PART NUMBERING.

When ordering discs please use the correct part number wherever possible. An example part number is explained below:- All AP Racing brake discs are individually marked with the following information:

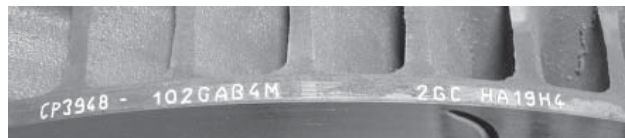
**PART NUMBERING EXPLANATION**

Basic Disc (casting) Type

Disc Face Suffix (see below)

CP3581 - 1042 CG8 B1

Stroke Number

Bedding (if applicable)

HANDING

- Even Stroke Numbers are Right Hand
- Odd Stroke Numbers are Left Hand

FACE TYPES

- P = Plain / - D = Drilled Face / - G = Straight Grooves G3 = When G appears with a digit, this denotes the number of grooves per face on the disc. e.g. G4/G6/CG8/CR12 etc. / - CG = Curved Grooves
- GD = Grooved & Drilled / - CR = Curved Grooved backward facing running out to O/D. / - PG = Partial Groove. / - RD = Radius Drilled
- SD = Similar to RD but with smaller holes. / - RA = J Hook Design, grooves run-out. / - GA = J Hook Design, grooves do not run-out.
- RC = J Hook as GA but with 3 hooks across face. / - B1 = A "B" and a Number added to the end of the part number i.e. CP3581-1042DB? means the disc has been pre-bedded with a particular pad material.

SAFETY AND CARE OF DISCS.

Cast iron brake discs should not normally be operated at bulk temperatures in excess of 610°C and above rotational speeds of 3000 revolutions per minute. Discs must be regularly and frequently inspected for excessive heat crazing and cracking. After heavy and prolonged use some surface crazing will often be evident, if this turns into distinct surface cracks which are radiating towards the inside or outside diameter the disc should be changed. Discs with cracks emanating from mounting holes / slots, inside diameter, scallops, or outside diameter should be changed immediately.

IF IN DOUBT REPLACE.

BRAKE DISCS - Carbon / Carbon - General Information

INTRODUCTION.

Carbon/Carbon brake discs & pads offer very lightweight construction together with excellent braking performance. Carbon/Carbon is also expensive but if managed correctly, mainly a question of temperature control, then wear rates and hence running costs can be surprisingly low. AP Racing has more than 20 years of experience with Carbon/Carbon brakes in F1 and Sportscar racing.

We recommend and supply a number of Hitco Carbon/Carbon materials which we consider to offer the best performance and braking characteristics together with low wear of any material currently available. This section on Carbon discs is designed as a users guide for reference only and we recommend you contact AP Racing technical section for more detailed information before finalising installation details.



COOLING REQUIREMENTS.

The uprights should be designed to provide a cooling air pathway of at least 140cm² area. Hitco Carbon/Carbon requires good face cooling. It is worth monitoring airflow / temperature on both inside and outside disc faces during testing.

It may be found that a larger face-cooling gap is required for the inside face to equalize the face temperatures. This is due to the tendency of the airflow to bypass this outlet when exiting the upright and flowing mainly up the outside face. The resultant temperature differential can lead to uneven wear, especially if temperature / wear is high.

BEDDING DISC AND PADS PRIOR TO RACE.

Because AP Racing Carbon/Carbon brake materials have lower operating temperatures compared to other carbon brake materials, it is easy to achieve running temperatures without the problem of glazing the rubbing faces. Blanking the brake ducts is not required in dry conditions.

When bedding the driver should apply hard brake pressure in short applications. Take care not to drag the brakes under lighter loads as this may result in glazing. If this occurs and the driver reports there is inadequate retardation, then the pads should be removed from the calipers and both these and the discs should have the rubbing faces de-glazed with coarse emery paper and dust thoroughly removed.

MONITORING TEMPERATURES.

The most reliable way of monitoring the disc temperature is by the application of indicating paints. Use of pit lane thermocouple temperatures is useful for achieving a front / rear balance. The green (430°C) and red (610°C) paints must only be used. The Orange paint in most kits should **not** be used as this will damage the disc. If the disc O/D is painted with either brown or grey antioxidant paint, this and the grey CVD coating must be completely removed from the section of the disc before the paints are applied. Failure to do this could result in the indicating paint not changing colour, regardless of the operating temperature.

The temperature paint colour change is not instantaneous, but is accelerated by higher temperature and the time at temperature is cumulative. It is therefore advisable that at least 5 consecutive laps at representative speed are completed before reference to the temperature paint. Turning the green paint 75% across disc width is adequate. Turning the red paint just on the disc edges (2-3mm) is acceptable.

Running the material at higher temperatures will only result in increased wear rate. If the red paint has changed across the entire disc width, extra cooling must be applied. Continued running at this level of temperature may result in excessively high wear rates, and can lead to weakening of the disc structure.

DISC CONDITION.

Experience has shown that if normal operating guidelines are adhered to, Hitco Carbon/Carbon discs can safely be used down to their minimum thickness.

However if for any reason discs are used at very high temperatures it is possible for oxidation to occur throughout the material, this will severely weaken the Carbon structure. Therefore avoid running the disc with the red paint fully blown.

RECONDITIONING.

The Carbon Discs may exhibit uneven surfaces when worn. AP Racing offer a reconditioning service to re-machine disc faces.

MAINTENANCE.

If the discs and pad surfaces are worn unevenly they can be machined flat and parallel again. A fixture should be made to mount the disc on its mounting flange, and both sides should be machined at the same setting. Failure to do this may result in thick / thin which will cause pedal "pulsing" and vibration. For H13.5 discs only brown antioxidant paint is available from AP Racing (CP2872-145) and should be "touched-up" as required.

NOTE: Do not attempt to degrease the material with any solvents. If a Carbon disc is contaminated with oil or other please contact AP Racing for advice

WEAR PREDICTION.

If high brake wear is anticipated in the race, it is important to complete as many laps as possible in "race trim" (using a measured set of carbon) during practice.

A race wear prediction can then be made using a similar system to that detailed on the AP Racing "Carbon Brake Life Evaluation" sheet which can be obtained from AP Racing or from our website. All laps (including "in" and "out" laps) are included and a 1.5 x safety factor applied.

WEAR GUIDE.

AP Racing carbon discs have disc wear indicators in the brake face and vary depending on the new thickness.

- **37.00mm Thick** discs which have angles vents have a 16mm diameter indicator 1.00mm deep a 12.00 diameter indicator 3.50mm deep and there is a triangle wear indicator that is 6.00mm deep. This indicator shows the direction of rotation of the disc and is the last wear indicator.

All these indicators are on both sides of the disc. These are there to give the user a guide as to the disc wear and when the triangle indicators are no longer showing the disc is at or below 25mm its minimum thickness.

- **35.00mm Thick** discs that use angles vents have a 12.00mm indicator 2.50mm deep and there is a triangle wear indicator that is 5.00mm deep. This indicator shows the direction of rotation of the disc and is the last wear indicator.

All these indicators are on both sides of the disc. These are there to give the user a guide as to the disc wear and when the triangle indicators are no longer showing the disc is at or below 25mm its minimum thickness.

- **35.00mm Discs** which run non handed vents have a 12.00mm diameter indicator 2.50mm deep and an 8.00mm diameter indicator 5.00mm deep. When the 8.00mm diameter indicator is no longer visible on both sides this will show the disc at or below its 25.00mm minimum thickness.

NOTE:- In some circumstances one disc face may wear more than the other. If the disc shows signs of this you must make sure you keep a minimum disc thickness of 5.00mm between the outer disc braking face and the inner cooling vent hole in the centre of the discs .

TECHNICAL CONTACTS.

AP Racing offer several different Carbon materials for different applications and operating conditions. The choice of the best material for given application is complex. Please contact AP Racing Technical Section (racetech@apracing.co.uk) or one of the following engineers directly.

Note: See page 50 for Part Numbering.

- **Nic Olson** **Key Account / Race Engineer, GT / ALMS.**
 - Office Tel: +44 (0)24 7688 3314
 - Mobile: +44 (0)7768 270 883
 - E-mail: nic.olson@apracing.co.uk

- **Peter Harris** **Key Account / Race Engineer, GT / WTC.**
 - Office Tel: +44 (0) 24 7688 3305
 - Mobile: +44 (0) 7881 782 561
 - E-mail: peter.harris@apracing.co.uk