

# A1 INSTALLATION DRAWING

IF THIS DOCUMENT IS PRINTED IN HARDCOPY, IT IS FOR INFORMATION USE ONLY AND THEREFORE IS NOT SUBJECT TO UPDATING CONTROLS. ALWAYS REFER TO SOLIDWORKS VIEWER FOR LATEST ISSUE

FIRST ANGLE PROJECTION

THIS DRAWING IS CONFIDENTIAL AND IS SUPPLIED ON THE EXPRESS CONDITION THAT IT SHALL NOT BE LOANED OR COPIED OR DISCLOSED TO ANY OTHER PERSON OR USED FOR ANY OTHER PURPOSE WITHOUT THE WRITTEN CONSENT OF AP RACING LTD.



AP Racing  
Wheler Road  
Coventry  
CV3 4LB

Tel: +44 (0) 24 7663 9595  
Fax: +44 (0) 24 7663 9559  
e-mail: engineering@apracings.co.uk  
Web site: http://www.apracings.com

© AP Racing Ltd. 2005

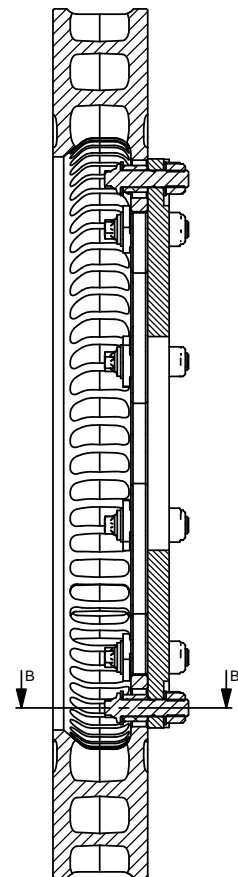

SECTION A-A  
SCALE 1:1

DISC MOUNTING PCD. (VARIOUS)  
SEE INDIVIDUAL DISC CUSTOMER DRAWING  
FOR RECOMMENDED MOUNTING PCD

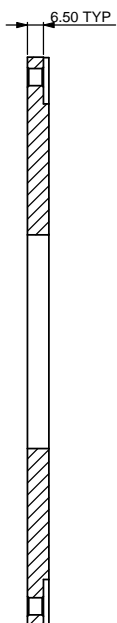

SECTION C-C  
SCALE 1:1

APPROX O/D = PCD + 15  
NOTE: ENSURE THAT THE OD OF THE BELL WILL NOT FOUL THE PAD BACKING PLATE WHEN THE PADS ARE FULLY WORN.

MOUNTING BELL DIMENSIONS TO SUIT AP RACING DISCS AND BOBBINS.  
ALL OTHER DIMENSIONS ARE AT THE DISCRETION OF THE CUSTOMER.

'X' HOLES  $\phi 6.45$  THRO' EQUI-SPACED  
 $\phi 6.40$   
(FINAL SIZE, AFTER ANY TREATMENT.)  
CHF.  $0.5 \times 45^\circ$  EACH SIDE  
FOR QUANTITY 'X' SEE INDIVIDUAL  
DISC CUSTOMER DRAWING.

$\pm \phi 0.10$  Z

## DISC INSTALLATION

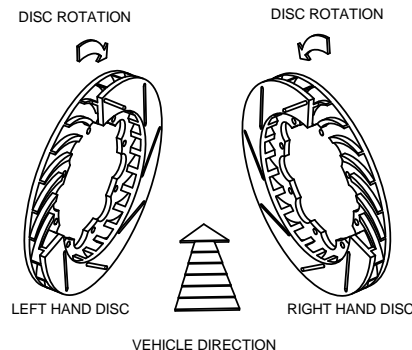

IT MAY BE NECESSARY TO ARRANGE CUT-OUTS AS ILLUSTRATED TO ENCOURAGE DISC COOLING ON THE BELL SIDE OF THE DISC  
SEE AP RACING CATALOGUE FOR GUIDANCE ON DISC COOLING AND OTHER ADVICE ON DISCS.

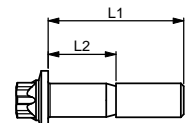

1/4" UNF 6 LOBE BOLT

BOLT CHART		
PART NO.	L1	L2
CP3845-107	30.2	17.5
CP3845-102	27	14.3
CP3845-101	25.4	12.7
CP3845-100	22.2	9.5
CP3845-108	17.9	9.5

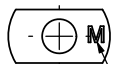

NOTE:  
BOBBINS HAVE A LETTER STAMPED ON THEM THAT CORRESPONDS TO THE LAST LETTER IN THE PART NO.

BOBBIN CHART	
BOBBIN PART NO.	BOBBIN LENGTH L3
CP7016-120MM	6.525
CP7016-126MV	7.075
CP7016-132MX	7.775
CP7016-139MS	7.925

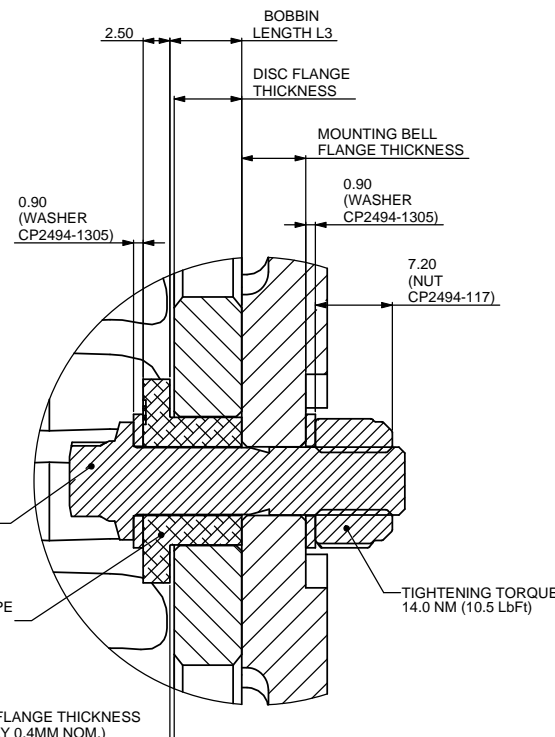

SECTION B-B  
SCALE 4:1

ALL DIMENSIONS ARE IN MILLIMETRES UNLESS OTHERWISE SPECIFIED

Issue No.	Alterations		Zone	Initials
	Date & No.	Particulars		
1	09/03/11 B6188	FIRST ISSUE		JH

SCALE 2:1	SHEET 1 OF 1
DRAWN	jheritage
APPROVED	
DERIVED FROM	
TITLE WIDE BOBBIN (PLAIN HOLE) INSTALLATION DRAWING	
DRG NO.	CP7016-1CD