

A1 INSTALLATION DRAWING

IF THIS DOCUMENT IS PRINTED IN HARDCOPY, IT IS FOR INFORMATION USE ONLY AND THEREFORE IS NOT SUBJECT TO UPDATING CONTROLS. ALWAYS REFER TO SOLIDWORKS VIEWER FOR LATEST ISSUE



THIS DRAWING IS CONFIDENTIAL AND IS SUPPLIED ON THE EXPRESS CONDITION THAT IT SHALL NOT BE LOANED OR COPIED OR DISCLOSED TO ANY OTHER PERSON OR USED FOR ANY OTHER PURPOSE WITHOUT THE WRITTEN CONSENT OF AP RACING LTD.



AP Racing
Wheler Road
Coventry
CV3 4LB

Tel: +44 (0) 24 7663 9595
Fax: +44 (0) 24 7663 9559
e-mail: engineering@apracings.co.uk
Web site: http://www.apracings.com

© AP Racing Ltd. 2014

CP7381, Ø184mm (7.25") SINTERED CLUTCH ASSEMBLY

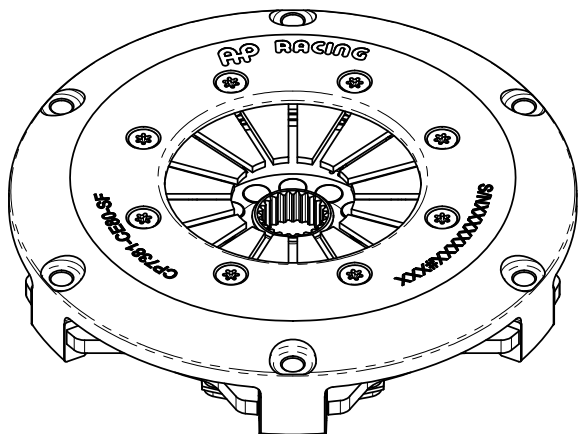

RECOMMENDED RELEASE BEARING :

STEEL CAGED, ROUND NOSED BALL TYPE BEARING TO BE FREE OF SPRING FINGERS WHEN CLUTCH IS FULLY ENGAGED.

CP3457-2 STANDARD RELEASE BEARING (OUTER RACE ROTATES)
CP3457-6 HIGH SPEED RELEASE BEARING (INNER RACE ROTATES).

RELEASE TRAVEL TO BE LIMITED TO 5.50mm MAXIMUM

SET UP HEIGHT
WORN MAXIMUM
(SEE TABLE)

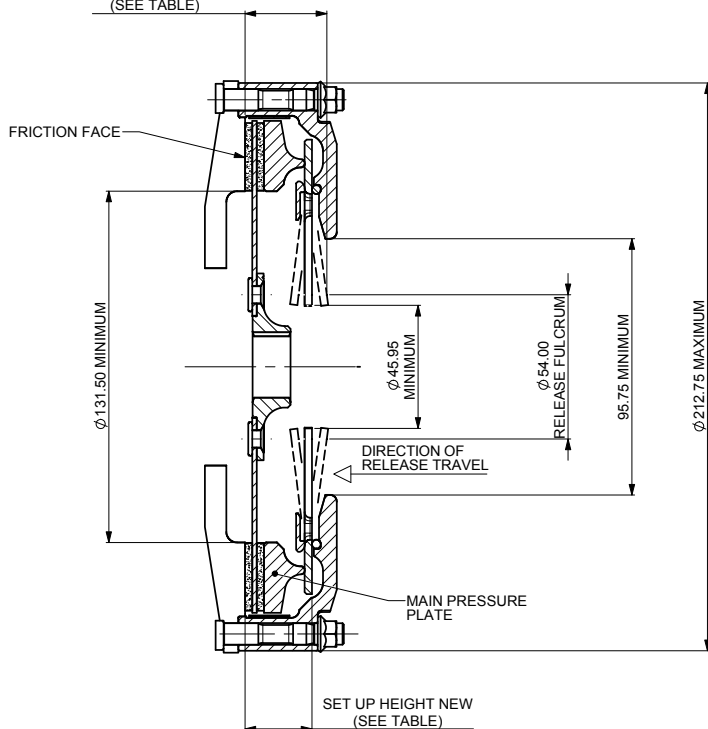

CP7381 CLUTCH FAMILY

MAXIMUM DYNAMIC TORQUE CAPACITY

(Nm)	419	263	162				
(ft.lb)	309	194	119				

RELEASE LOAD

Max. Peak New (N)	3500	2400	1600				
Max. Peak Worn (N)	4400	3300	2200				

WEAR IN (See Note)

	0.75	0.75	0.75				
--	------	------	------	--	--	--	--

Set Up Height New	26.92	27.71	26.89				
Set Up Height Worn - MAX	24.64	25.40	24.60				

(Set Up Height is calculated from the flywheel friction face.)

Release Ratio	4.10	4.10	4.10				
---------------	------	------	------	--	--	--	--

Estimated Assembly Mass (Excluding Driven Plate) = 2.24 Kg

Estimated Assembly Inertia (Excluding Driven Plate) = 0.014 Kgm²

Estimated Driven Plate Inertia - See Sheet 2

PERFORMANCE SUFFIX	CE	OE	NE				
For Reference							
Diaphragm Spring Rate	CRV	ORA	GRN				
Clutch Ratio	EHR	EHR	EHR				

MATERIAL SUFFIX	DRIVE PLATE MATERIAL	DRIVE PLATE THICKNESS				
80	CERAMETALLIC	7.11mm				

FLYWHEEL TYPE

	SUFFIX	COMMENTS
FLAT FLYWHEEL	FF	FOR INSTALLATION DATA SEE SHEET 2
STEPPED FLYWHEEL	SF	FOR INSTALLATION DATA SEE SHEET 2

Sample AP Racing Part No. **CP7381-CE80-SF**

WEAR IN

THIS CLUTCH HAS BEEN DESIGNED FOR THE WEAR IN INDICATED ABOVE,

DRIVEN PLATE THICKNESS NEW: 7.11mm NOMINAL

DRIVEN PLATE THICKNESS WORN: 6.36mm MIN

DRIVEN PLATES - SEE SHEET 2

TYPICAL DRIVEN PLATE SIZES - CONTACT AP RACING FOR OTHERS AVAILABLE

SPLINE	3 PADDLE (CP8300 TYPE)	4 PADDLE (CP8400 TYPE)	6 PADDLE (CP8600 TYPE)	ORGANIC (CP5386 TYPE)
1" X 23T	CP8300-A036H	CP8400-A036H	CP8600-A036H	CP5386-10
7/8" x 20T	CP8300-A026	CP8400-A026	CP8600-A026	CP5386-12
1 5/32" x 26T	CP8300-A040	CP8400-A040	CP8600-A040	N/A
29.0 x 10T	CP8300-A008	CP8400-A008	CP8600-A008	CP5386-15

ISSUE NO.	Alterations			Zone	Initials
	Date & No.	Particulars			
FOR ALL		ISSUE RECORDS PRE SEE ARCHIVE COPY		13	
9	07/10/14 C4778	DRAWING UPDATED TO CURRENT STANDARD SUH CHANGES (AS NOW MEASURED FROM FRICTION FACE NOT FLYWHEEL STEP) CE ASSEMBLY: 27.43 WAS 29.88, 25.14 WAS 27.51, 30.65 WAS 32.90 OE ASSEMBLY: 28.23 WAS 30.63, 25.90 WAS 28.23, 31.44 WAS 33.65 NE ASSEMBLY: 27.41 WAS 30.42, 25.10 WAS 28.05, 30.62 WAS 33.43.			bcB
10	03/03/15 C4872	SUH CHANGES: CE - 26.92/24.64 WAS 27.43/25.14 30.65 WAS 30.65 OE - 27.71/25.40 WAS 28.23/25.90 30.92 WAS 31.44 NE - 28.69/24.60 WAS 27.41/25.10 30.11 WAS 30.62			JG

SCALE 1:1	SHEET 1 OF 2
DRAWN	DAVID CONSTABLE-BERRY
APPROVED	
DERIVED FROM	CP7972
TITLE	Ø184 (7.25") SINGLE PLATE CLUTCH INSTALLATION
DRG NO.	CP7381-1CD

A1 INSTALLATION DRAWING

IF THIS DOCUMENT IS PRINTED IN HARDCOPY, IT IS FOR INFORMATION USE ONLY AND THEREFORE IS NOT SUBJECT TO UPDATING CONTROLS. ALWAYS REFER TO SOLIDWORKS VIEWER FOR LATEST ISSUE



THIS DRAWING IS CONFIDENTIAL AND IS SUPPLIED ON THE EXPRESS CONDITION THAT IT SHALL NOT BE LOANED OR COPIED OR DISCLOSED TO ANY OTHER PERSON OR USED FOR ANY OTHER PURPOSE WITHOUT THE WRITTEN CONSENT OF AP RACING LTD.



AP Racing
Wheler Road
Coventry
CV3 4LB

Tel: +44 (0) 24 7663 9595
Fax: +44 (0) 24 7663 9559
e-mail: engineering@apracings.co.uk
Web site: http://www.apracings.com

© AP Racing Ltd. 2014

FLYWHEEL DIMENSIONS

STEPPED FLYWHEEL SUFFIX -SF

FLYWHEEL DIMENSIONS

FLAT FLYWHEEL SUFFIX -FF

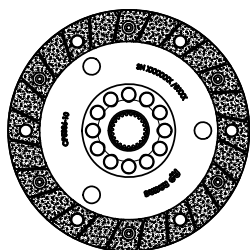
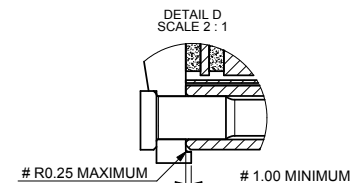
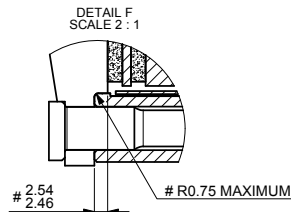
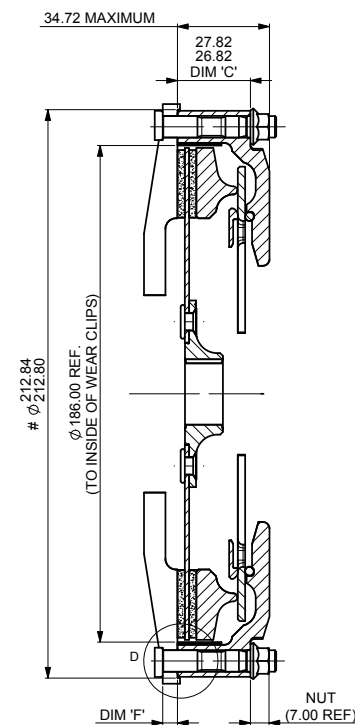
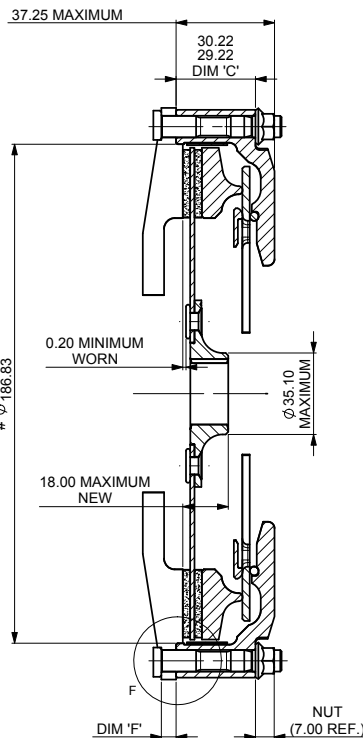
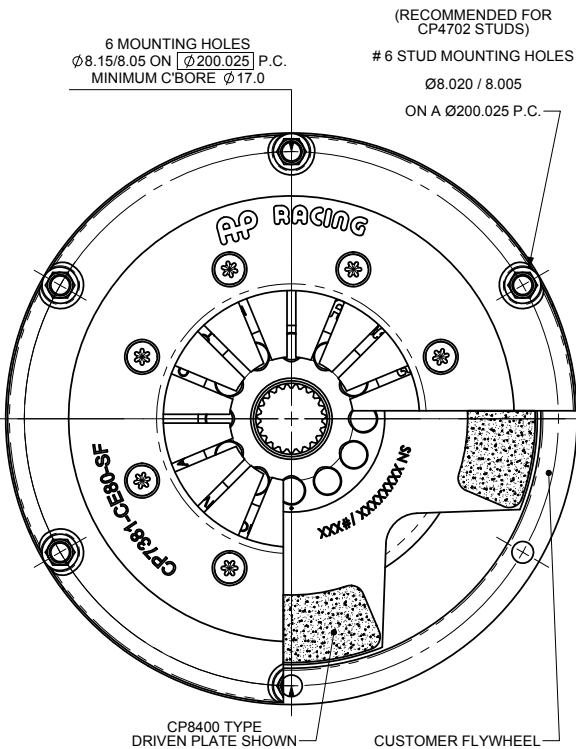

CP5386 TYPE ORGANIC DRIVEN PLATE
NOTE: (NOT TO EXCEED 7000rpm)
1:2 SCALE

PLATE TYPE	TYPICAL ASSEMBLY MASS	TYPICAL ASSEMBLY INERTIA
CP8300	0.453kg	0.0016kg/m ²
CP8400	0.524kg	0.0020kg/m ²
CP8600	0.669kg	0.0029kg/m ²
CP5386	0.582kg	0.0023kg/m ²

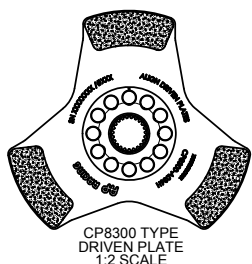

CP8300 TYPE DRIVEN PLATE
1:2 SCALE

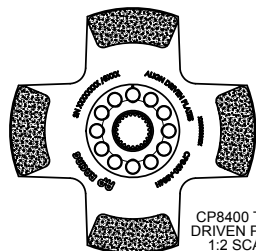

CP8400 TYPE DRIVEN PLATE
1:2 SCALE

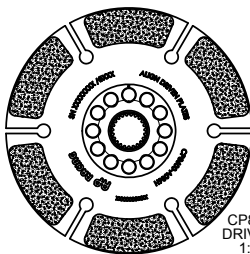

CP8600 TYPE DRIVEN PLATE
1:2 SCALE

RECOMMENDED CLUTCH MOUNTING :

(FOR ALL TYPES OF ASSEMBLY)
M8 x 1.0, CP4702 FAMILY STUD AND K-LOCK NUT.
TIGHTENING TORQUE : 19Nm (14 ft.lb)

LENGTH OF STUD REQUIRED TO BE CALCULATED THUS :

STUD LENGTH = DIMENSIONS 'C' + 'F' + NUT

THIS CALCULATED LENGTH TO BE ROUNDED UP TO THE NEXT AVAILABLE STANDARD STUD LENGTH.

SUGGESTED FLYWHEEL MATERIAL:

0.35/0.45% CARBON STEEL, BRINELL 200 MIN. OR SUITABLE MATERIAL FOR HIGH RPM.
FRICTION FACE TO BE FINE TURNED AND GROUND SMOOTH AND FLAT. RUN OUT AT R77.2, ≤0.08 WHEN ASSEMBLED TO CRANKSHAFT.

Issue No.	Alterations		Zone	Initials
	Date & No.	Particulars		
-	-	SEE SHEET 1 FOR ISSUE INFORMATION.	-	-

SCALE 1:1	SHEET 2 OF 2
DRAWN	DAVID CONSTABLE-BERRY
APPROVED	
DERIVED FROM	CP7972
TITLE	
Ø184 (7.25") SINGLE PLATE CLUTCH INSTALLATION	
DRG NO.	CP7381-1CD